



FITTING INSTRUCTIONS FOR CP0557 CRASH PROTECTORS



PICTURE A

THIS KIT CONTAINS THE ITEMS PICTURED AND LABELLED OVER PAGE.

SOME PARTS MAY BE SHOWN FOR CLARITY OF INSTRUCTIONS ONLY.

DO NOT PROCEED UNTIL YOU ARE SURE ALL PARTS ARE PRESENT.

PLEASE READ ALL INSTRUCTIONS BEFORE PROCEEDING.

**IF IN ANY DOUBT WHEN FITTING OUR PRODUCTS, CONSULT ONE OF OUR DEALERS
OR HAVE FITTED BY A QUALIFIED TECHNICIAN.**

PLEASE NOTE THAT THE WAY THE KIT IS PACKED DOES NOT NECESSARILY REPRESENT THE WAY OF
MOUNTING TO THE BIKE.

IN THE EVENT OF RUBBER WASHERS BEING USED TO HOLD COMPONENTS ONTO BOLTS,
THESE RUBBER WASHERS CAN BE THROWN AWAY.

DIGITAL COPIES OF THESE INSTRUCTIONS ARE AVAILABLE FROM:

WWW.RG-RACING.COM

R&G Racing

Unit 1, Shelley's Lane, East Worldham, Alton, Hampshire, GU34 3AQ

Tel: +44 (0)1420 89007 Fax: +44 (0)1420 87301 www.rg-racing.com Email: info@rg-racing.com



<u>TOOLS REQUIRED</u>	<u>GENERAL TORQUE SETTINGS</u>
<ul style="list-style-type: none"> • Socket set including a 17mm socket • Ratchet • Torque wrench (up to 50Nm). 	<p>M4 BOLT = 8Nm</p> <p>M5 BOLT = 12Nm</p> <p>M6 BOLT = 15Nm</p> <p>M8 BOLT = 20Nm</p> <p>M10 BOLT = 40Nm</p> <p>M12 BOLT = 40Nm</p>

LEGEND

ITEM NO.	DESCRIPTION	QTY
ITEM 1	CRASH BOBBIN (BOO61 WITH CS340)	2
ITEM 2	SPACER (S1404)	2
ITEM 3	M12x1.25x170mm HEX BOLT	2
ITEM 4	M12 WASHER	2
ITEM 5	M12 LOCKING WASHER	2
ITEM 6	BOBBIN CAP (BC0002)	2

EXPLODED ASSEMBLY VIEW

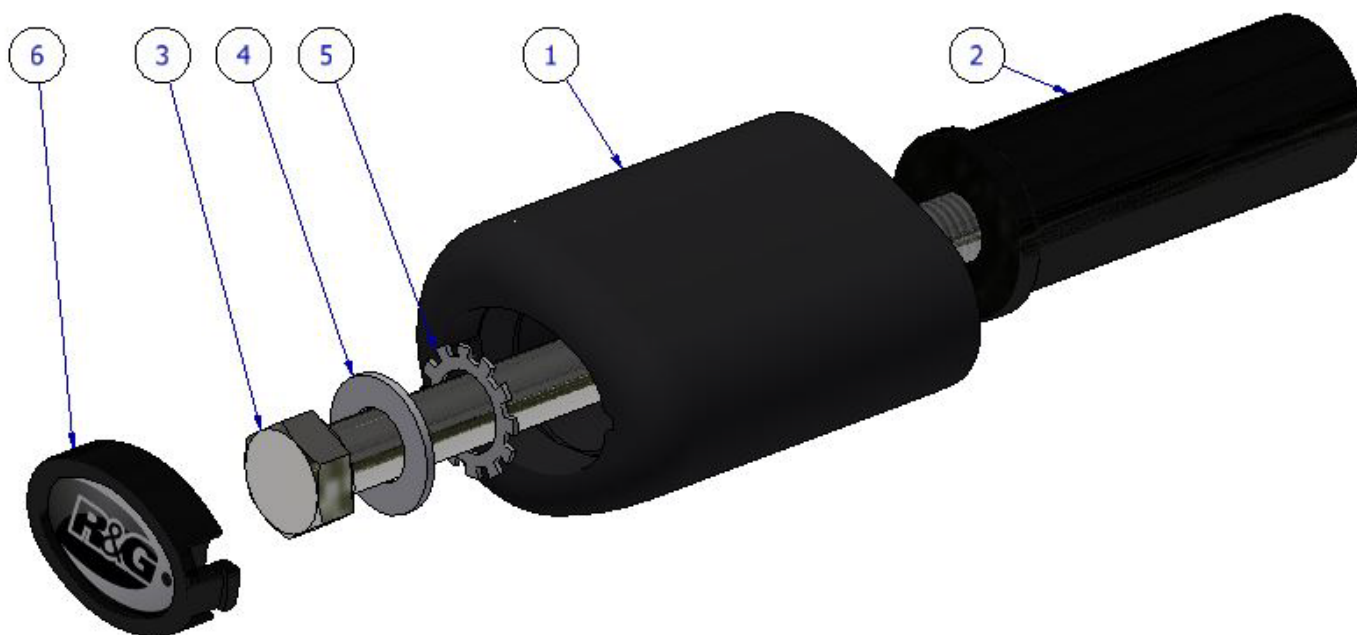

R&G Racing

Unit 1, Shelley's Lane, East Worldham, Alton, Hampshire, GU34 3AQ

Tel: +44 (0)1420 89007 Fax: +44 (0)1420 87301 www.rg-racing.com Email: info@rg-racing.com

**PICTURE B**

FITTING INSTRUCTIONS

Before removing engine bolts, ensure the bike is upright and supported by a suitable engine stand or jack placed under the sump of the motorbike to support the partial weight of the engine, this will prevent the engine from moving during fitting. DO NOT REMOVE MORE THAN 1 ENGINE BOLT AT ANY TIME.

- Remove the OEM bolt in position arrowed in **picture B** on page 3.
- Assemble the crash protector kit as shown in the **EXPLODED ASSEMBLY VIEW**.
- Offer this assembly into position as shown in **picture A** on page 1. Finally tighten the crash protector bolts until you feel some compression from inside the protector using 17mm socket and wrench. **PLEASE NOTE THE CRASH PROTECTOR MUST BE POSITIONED AS SHOWN IN THE ASSEMBLY DIAGRAMS WITH BIGGER END TOWARD FRONT OF BIKE.** Turn a little more so that you feel the compression increase slightly. Then apply a quarter turn. **Tighten to 40Nm of torque (do not exceed this figure, as damage can occur to the motorcycle and the bolt).**
- If not already fitted, fit bubble sticker into recess of crash protector cap (**ITEM 6**).
- Fit crash protector cap (**ITEM 6**) into the crash protector (**ITEM 1**).

REPEAT THE ABOVE STEPS FOR BOTH SIDES OF THE MOTORCYCLE.

R&G Racing

Unit 1, Shelley's Lane, East Worldham, Alton, Hampshire, GU34 3AQ

Tel: +44 (0)1420 89007 Fax: +44 (0)1420 87301 www.rg-racing.com Email: info@rg-racing.com



See more R&G products for your Motorcycle On:

ISSUE 1 - 23/08/2023 (JH)

CONSUMER NOTICE

The catalogue description and any exhibition of samples are only broad indications of the Products and R&G may make design changes which do not diminish their performance or visual appeal and supplying them in such state shall conform to the order. The Buyer acknowledges no representation or warranty (other than as to title) has been given or will apply to the Products other than those in R&G's order or confirmation and the Buyer confirms it has chosen the Products as being of merchantable quality and suitable for its particular purposes. Where R&G fits the Products or undertakes other services it shall exercise reasonable skill and care and rectify any fault free of charge unless the workmanship has been disturbed. The Buyer is responsible for ensuring that the warranty on the motorcycle is not affected by the fitting of the Products. On return of any defective Products R&G shall at its option either supply a replacement or refund the purchase money but shall not be liable if the Products have been modified or used or maintained otherwise than in accordance with R&G's or manufacturer's instructions and good engineering practice or if the defect arises from accident or neglect. Other than identified above and subject to R&G not limiting its liability for causing death and personal injury, it shall not be liable for indirect or consequential loss and otherwise its liability shall be limited to the amounts paid by the Buyer for the Products or the fitting or service concerned. These terms do not affect the Buyer's statutory rights.

R&G RACING RETURNS POLICY (NON-FAULTY GOODS)

Returns must be pre-authorized (if not pre-authorized the return will be rejected). Goods may only be returned direct to us if they were purchased direct from us (customer must prove if necessary). Otherwise to be returned to original vendor. Goods must be in re-sellable condition, in the opinion of R&G Racing. All returns are subject to a 25% restocking and handling fee (25% of the gross value exc. P&P – at the prevailing price at time of purchase). The customer must pay any and all carriage charges. No returns of discontinued products, unless within 14 days of purchase. This policy does not affect your statutory rights and does not refer to faulty goods.

R&G Racing

Unit 1, Shelley's Lane, East Worldham, Alton, Hampshire, GU34 3AQ

Tel: +44 (0)1420 89007 Fax: +44 (0)1420 87301 www.rg-racing.com Email: info@rg-racing.com



NOTICE DE MONTAGE POUR CP0557 PROTECTIONS CRASH



PHOTO A

CE KIT CONTIENT LES ARTICLES ILLUSTRES ET ETIQUETES SUR LA PAGE.

CERTAINES PARTIES PEUVENT ETRE PRESENTES UNIQUEMENT POUR LA CLARTE DES INSTRUCTIONS.

NE PAS PROCEDER AU MONTAGE TANT QUE VOUS N'ETES PAS SUR QUE TOUTES LES PIECES SOIENT PRESENTES.

VEUILLEZ LIRE TOUTES LES INSTRUCTIONS AVANT DE CONTINUER.

EN CAS DE DOUTE LORS DU MONTAGE DE NOS PRODUITS, CONSULTEZ UN DE NOS REVENDEURS OU FAITES APPEL A UN TECHNICIEN QUALIFIÉ.

VEUILLEZ NOTER QUE LA FAÇON DONT LE KIT EST EMBALLE NE REPRESENTE PAS NECESSAIREMENT LA MANIERE DE LE MONTER SUR LA MOTO.

SI DES RONDELLES EN CAOUTCHOUC SONT UTILISEES POUR MAINTENIR LES COMPOSANTS SUR LES BOULONS, ELLES PEUVENT ETRE JETEES.

NOTICE DISPONIBLE AU TELECHARGEMENT SUR :

WWW.RG-RACING.COM

R&G Racing

Unit 1, Shelley's Lane, East Worldham, Alton, Hampshire, GU34 3AQ

Tel: +44 (0)1420 89007 Fax: +44 (0)1420 87301 www.rg-racing.com Email: info@rg-racing.com



OUTILS REQUIS	VALEURS DE SERRAGE
<ul style="list-style-type: none"> • Clé à cliquet + douille 17mm • Cliquet • Clé dynamométrique (jusqu'à 50Nm). 	M4 BOULON = 8Nm M5 BOULON = 12Nm M6 BOULON = 15Nm M8 BOULON = 20Nm M10 BOULON = 40Nm

LÉGENDE

ARTICLE NO.	DESCRIPTION	QTÉ
ARTICLE 1	PROTECTION CRASH (BO061 AVEC CS340)	2
ARTICLE 2	ENTRETOISE (S1404)	2
ARTICLE 3	M12x1.25x170mm BOULON	2
ARTICLE 4	M12 RONDELLE	2
ARTICLE 5	M12 RONDELLE DE BLOCAGE	2
ARTICLE 6	CAPUCHON DE PROTECTION (BC0002)	2

VUE D'ENSEMBLE

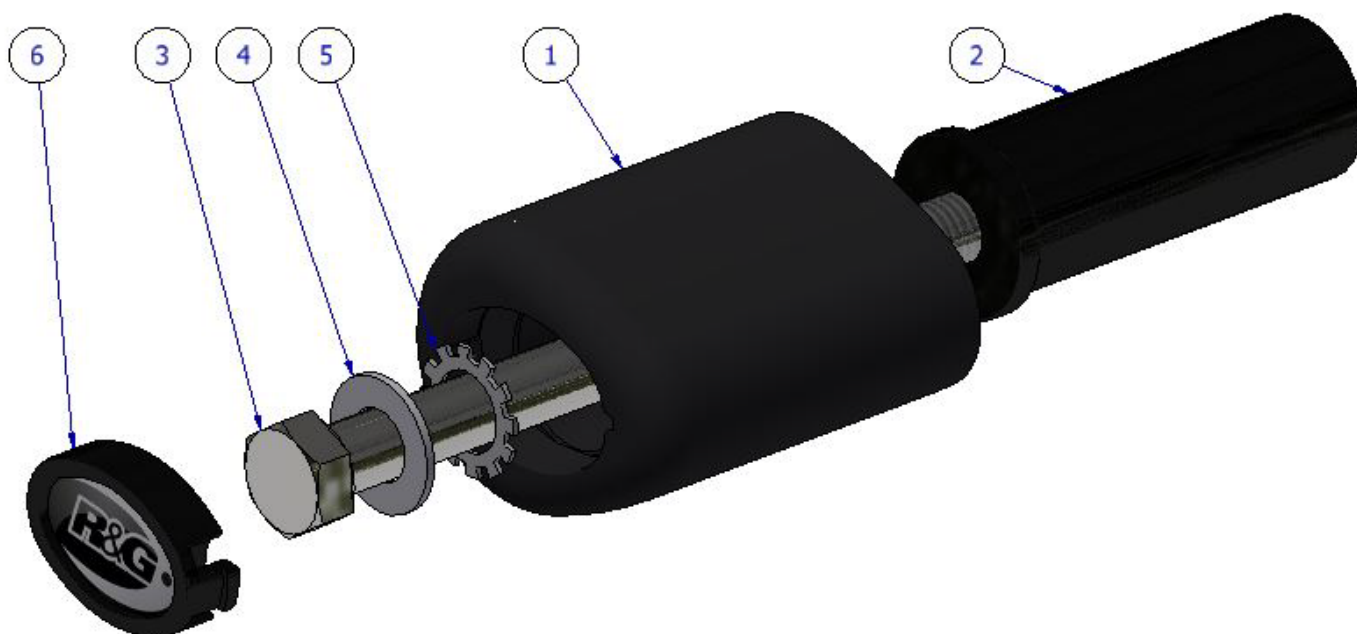

R&G Racing

Unit 1, Shelley's Lane, East Worldham, Alton, Hampshire, GU34 3AQ

Tel: +44 (0)1420 89007 Fax: +44 (0)1420 87301 www.rg-racing.com Email: info@rg-racing.com

**PHOTO B**

NOTICE DE MONTAGE

Avant de retirer les boulons du moteur, assurez-vous que la moto soit droite et soutenue par un support moteur ou un cric approprié placé sous le carter de la moto pour supporter une partie du poids du moteur, cela évitera que le moteur bouge pendant le montage. NE PAS RETIRER PLUS D'UN BOULON DE MOTEUR À LA FOIS.

- Retirez le boulon d'origine dans la position indiquée par la flèche sur la photo B à la page 3.
- Assemblez le kit de protection crash comme indiqué sur la VUE D'ASSEMBLAGE ÉCLATÉE.
- Proposez cet ensemble en position comme indiqué sur la photo A à la page 1. Enfin, serrez les boulons de la protection jusqu'à ce que vous sentiez une certaine compression de l'intérieur de la protection à l'aide d'une douille de 17 mm et d'une clé. VEUILLEZ NOTER QUE LA PROTECTION CONTRE CRASH DOIT ÊTRE POSITIONNÉE COMME INDIQUÉ SUR LES SCHÉMAS D'ASSEMBLAGE AVEC LA PLUS GRANDE EXTRÉMITÉ VERS L'AVANT DE LA MOTO. Tournez encore un peu pour sentir la compression augmenter légèrement. Appliquez ensuite un quart de tour. Serrez jusqu'à 40 Nm de couple (ne dépassez pas ce chiffre, car cela pourrait endommager la moto et le boulon).
- S'il n'est pas déjà installé, placez l'autocollant à bulles dans le creux du capuchon de protection de la protection (ARTICLE 6).
- Monter le capuchon de protection crash (ARTICLE 6) dans la protection crash (ARTICLE 1).

RÉPÉTEZ LES ÉTAPES CI-DESSUS POUR LES DEUX CÔTÉS DE LA MOTO.

R&G Racing

Unit 1, Shelley's Lane, East Worldham, Alton, Hampshire, GU34 3AQ

Tel: +44 (0)1420 89007 Fax: +44 (0)1420 87301 www.rg-racing.com Email: info@rg-racing.com



MONTAGEANLEITUNG FÜR CP0557 STURZPADS



ABBILDUNG A

ALLE KIT-TEILE SIND AUF DEN NACHFOLGENDEN SEITEN ABGEBILDET UND GEKENNZEICHNET.

DIE ABGEBILDETEN TEILE DIENEN LEDIGLICH ZUR ERKLÄRUNG.

ÜBERPRÜFEN SIE ZUERST, DASS ALLE TEILE VORHANDEN SIND.

LESEN SIE DIE MONTAGEANLEITUNG KOMPLETT DURCH, BEVOR SIE ANFANGEN.

WENN SIE BEI DER MONTAGE DIESES PRODUKTES UNSICHER SIND, BITTE EINEN UNSERER HÄNDLER KONTAKTIEREN ODER DAS KIT VON EINEM QUALIFIZIERTEN ZWEIRAD-MECHANIKER MONTIEREN LASSEN.

DIE VERPACKUNG DER TEILE STELLT NICHT DIE REIHENFOLGE DER MONTAGE DAR.

HINWEIS FÜR KITS MIT PLASTIKUNTERLEGSCHLEIBEN AN DEN SCHRAUBEN –
DIESE PLASTIK-UNTERLEGSCHLEIBEN WERDEN NICHT FÜR DEN EINBAU BENÖTIGT.

EINE DIGITALE VERSION DIESER MONTAGEANLEITUNG KANN AUF FOLGENDER SEITE HERUNTERGELADEN WERDEN:

R&G Racing

Unit 1, Shelley's Lane, East Worldham, Alton, Hampshire, GU34 3AQ

Tel: +44 (0)1420 89007 Fax: +44 (0)1420 87301 www.rg-racing.com Email: info@rg-racing.com



WWW.RG-RACING.COM

<u>SIE BENÖTIGEN FOLGENDES WERKZEUG:</u>	<u>ALLGEM. ANZUGSDREHMOMENT</u>
<ul style="list-style-type: none"> • Steckschlüssel-Satz inkl. 17mm Steckschlüssel • Verlängerung • Drehmomentschlüssel (bis 50Nm) 	<p>M4 SCHRAUBE = 8Nm</p> <p>M5 SCHRAUBE = 12Nm</p> <p>M6 SCHRAUBE = 15Nm</p> <p>M8 SCHRAUBE = 20Nm</p> <p>M10 SCHRAUBE = 40Nm</p> <p>M12 SCHRAUBE = 40Nm</p>

LIEFERUMFANG

ARTIKEL NR.	BESCHREIBUNG	MENGE
ARTIKEL 1	STURZPAD (BOO61 MIT CS340)	2
ARTIKEL 2	DISTANZHALTER (S1404)	2
ARTIKEL 3	M12x1.25x170mm SECHSKANTSCHRAUBE	2
ARTIKEL 4	M12 UNTERLEGESCHEIBE	2
ARTIKEL 5	M12 ZAHNSCHEIBE	2
ARTIKEL 6	STURZPAD-SCHUTZKAPPE (BC0002)	2

EXPLOSIONSZEICHUNG - ZUSAMMENBAU

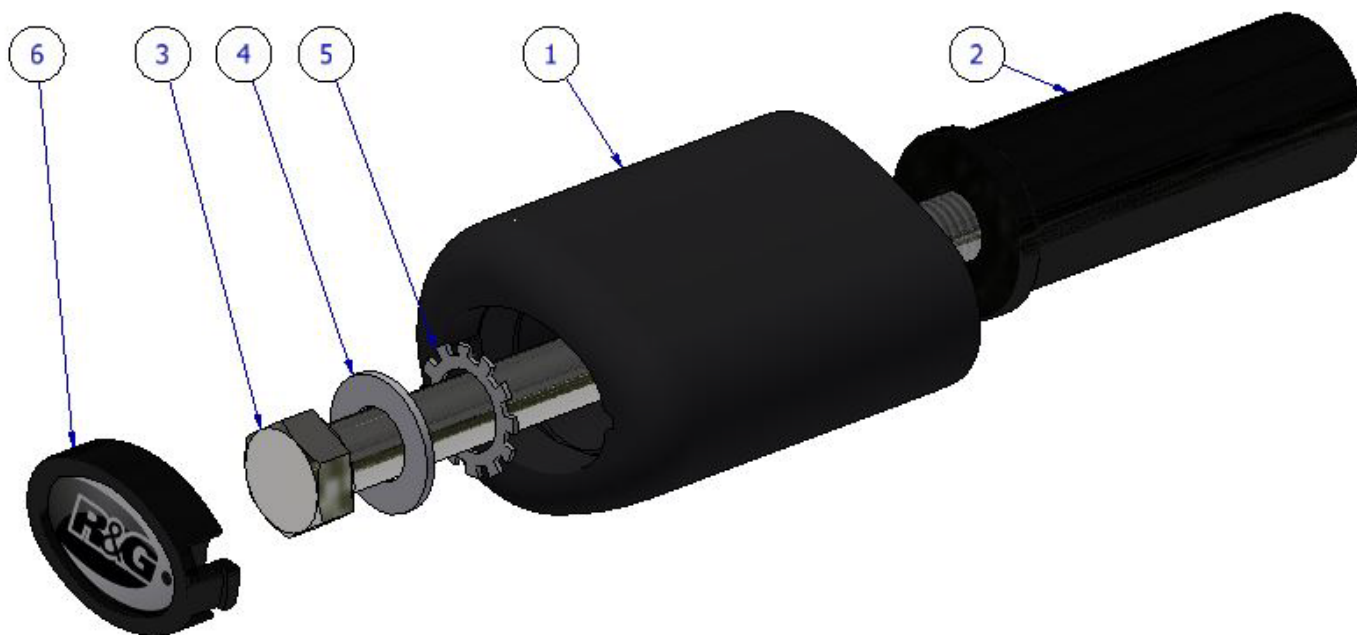

R&G Racing

Unit 1, Shelley's Lane, East Worldham, Alton, Hampshire, GU34 3AQ

Tel: +44 (0)1420 89007 Fax: +44 (0)1420 87301 www.rg-racing.com Email: info@rg-racing.com

**ABBILDUNG B****MONTAGEANLEITUNG**

Bevor Sie mit der Montage der R&G Sturz pads beginnen, stellen Sie sicher, dass das Motorrad aufrecht steht und der Motor von unten mit einem geeigneten Ständer/Heber unterhalb der Ölwanne gestützt wird. Dies wird verhindern, dass der Motor sich bei der Entfernung von Motorschrauben bewegt. **WÄHREND DER INSTALLATION DÜRFEN DIE SCHRAUBEN FÜR DEN MOTOR NUR EINZELN UND NIE GLEICHZEITIG ENTFERMT WERDEN.**

- Entfernen Sie die Originalschraube, die in **Abbildung B** auf Seite 3 mit einem Pfeil gekennzeichnet ist.
- Die Sturzpad-Einheit zusammenbauen wie in der **EXPLOSIONSZEICHNUNG ZUSAMMENBAU** abgebildet.
- Die Sturzpad-Einheit in Position bringen wie in **Abbildung A** auf Seite 1. Anschließend die Schrauben mit einem 17mm Steckschlüssel festziehen, bis Sie etwas Druck vom Inneren des Sturz pads spüren. **BITTE DARAUF ACHTEN, DASS DAS STURZPAD POSITIONIERT IST WIE IN DER ZEICHNUNG ZUSAMMENBAU – DAS GRÖßERE ENDE DES STURZPADS ZUM VORDERTEIL DES MOTORRADES GERICHTET.** Noch etwas drehen, bis Sie merken, dass der Druck sich leicht erhöht, dann noch eine Vierteldrehung anwenden. **Mit 40 Nm Anzugsmoment anziehen (40 Nm nicht überschreiten – dies kann zu einer Beschädigung des Motorrades und der Schraube führen).**
- Wenn noch nicht bereits montiert, montieren Sie einen Bubble-Aufkleber in der Vertiefung der Sturzpad-Schutzkappe (**Artikel 6**).
- Montieren Sie eine Sturzpad-Kappe (**Artikel 6**) am Sturzpad (**Artikel 1**).

WIEDERHOLEN SIE DIE OBEN BESCHRIEBENEN SCHRITTE AN BEIDEN SEITEN DES MOTORRADES.

R&G Racing

Unit 1, Shelley's Lane, East Worldham, Alton, Hampshire, GU34 3AQ

Tel: +44 (0)1420 89007 Fax: +44 (0)1420 87301 www.rg-racing.com Email: info@rg-racing.com