



FITTING INSTRUCTIONS FOR EH0130BKA EXHAUST HANGER



THIS KIT CONTAINS THE ITEMS PICTURED AND LABELLED OVER PAGE.

DO NOT PROCEED UNTIL YOU ARE SURE ALL PARTS ARE PRESENT.

PLEASE READ ALL INSTRUCTIONS BEFORE PRECEEDING.

**IF IN ANY DOUBT WHEN FITTING OUR PRODUCTS, CONSULT ONE OF OUR DEALERS
OR HAVE FITTED BY A QUALIFIED TECHNICIAN.**

PLEASE NOTE THAT THE WAY THE KIT IS PACKED DOES NOT NECESSARILY REPRESENT THE WAY OF
MOUNTING TO THE BIKE.

THE PARTS SHOWN MAY BE REPRESENTATIVE ONLY (FOR CLARITY OF INSTRUCTIONS ONLY).

IN THE EVENT OF RUBBER WASHERS BEING USED TO HOLD COMPONENTS ONTO BOLTS,
THESE RUBBER WASHERS CAN BE THROWN AWAY.



<u>TOOLS REQUIRED</u>	<u>MAXIMUM TORQUE SETTINGS</u>
<ul style="list-style-type: none"> • SET OF METRIC ALLEN KEYS <ul style="list-style-type: none"> • SOCKET SET • TORQUE WRENCH 	<ol style="list-style-type: none"> 1. M4 BOLT = 8Nm 2. M5 BOLT = 12Nm 3. M6 BOLT = 15Nm 4. M8 BOLT = 20Nm 5. M10 BOLT = 40Nm 6. M12 BOLT = 40Nm

LEGEND

ITEM No	DESCRIPTION	QTY
ITEM 1	EXHAUST HANGER (HB0130)	1
ITEM 2	M8 x 1.25 x 15mm BUTTON HEAD BOLT	2
ITEM 3	M8 x 1.25 x 20mm BUTTON HEAD BOLT	2
ITEM 4	M8 x 1.25 x 25mm BUTTON HEAD BOLT	1
ITEM 5	M8 WASHERS	4
ITEM 6	M8 NYLOC NUT	1
ITEM 7	BRANDED WASHER	2

ASSEMBLY DIAGRAM

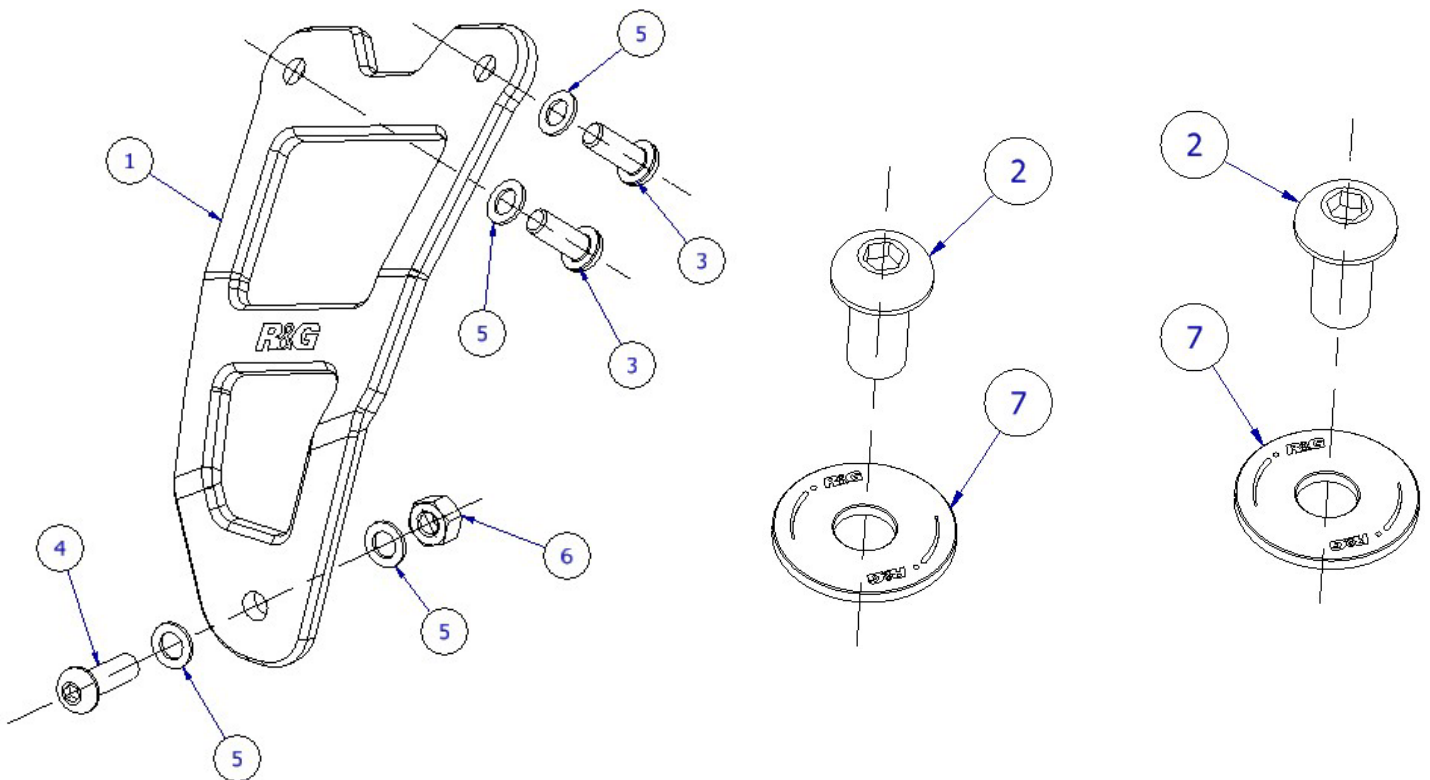



FITTING INSTRUCTIONS

REMOVE BEFORE FITTING

- Exhaust end can mounting bolt
- Right and left hand side passenger foot peg brackets

RHS EXHAUST BRACKET

1. Once all components are removed, place the new exhaust bracket up to the mounting holes and thread the two 20mm M8 bolts (**ITEM 3**) with a washer (**ITEM 5**) on each bolt, in and tighten. AS SHOWN IN THE ASSEMBLY DIAGRAM.
2. Make sure the OEM exhaust mounting hole is on the inside of the new exhaust bracket.
3. Place the 25mm bolt (**ITEM 4**) with a washer (**ITEM 5**) through the outside of the bracket and through the exhaust hole. The exhaust may need to be wiggled to align the holes.
4. Finally place the last washer (**ITEM 5**) and Nyloc nut (**ITEM 6**) onto the bolt on the back side and tighten.

LHS BLANKING PLATES

1. Place the two 15mm bolts (**ITEM 2**) through the two branded washers (**ITEM 7**).
2. Then insert into the two open holes where the LHS rear footpeg bracket was located.
3. Ensure to tighten all bolts using the General Torque Settings on Page 2.

Please note that it is your responsibility to ensure that no part of the exhaust hanger or exhaust assembly fouls or comes into contact with other parts of the machine. Do not ride the motorcycle until this aspect has been verified and you have compressed the rear suspension (if appropriate to the design of the motorcycle) to test this thoroughly.

Issue 1 - 14/03/2025 (JH)

CONSUMER NOTICE

The catalogue description and any exhibition of samples are only broad indications of the Products and R&G may make design changes which do not diminish their performance or visual appeal and supplying them in such state shall conform to the order. The Buyer acknowledges no representation or warranty (other than as to title) has been given or will apply to the Products other than those in R&G's order or confirmation and the Buyer confirms it has chosen the Products as being of merchantable quality and suitable for its particular purposes. Where R&G fits the Products or undertakes other services it shall exercise reasonable skill and care and rectify any fault free of charge unless the workmanship has been disturbed. The Buyer is responsible for ensuring that the warranty on the motorcycle is not affected by the fitting of the Products. On return of any defective Products R&G shall at its option either supply a replacement or refund the purchase money but shall not be liable if the Products have been modified or used or maintained otherwise than in accordance with R&G's or manufacturer's instructions and good engineering practice or if the defect arises from accident or neglect. Other than identified above and subject to R&G not limiting its liability for causing death and personal injury, it shall not be liable for indirect or consequential loss and otherwise its liability shall be limited to the amounts paid by the Buyer for the Products or the fitting or service concerned. These terms do not affect the Buyer's statutory rights.

R&G RETURNS POLICY (NON-FAULTY GOODS)

Returns must be pre-authorized (if not pre-authorized the return will be rejected). Goods may only be returned direct to us if they were purchased direct from us (customer must prove if necessary). Otherwise to be returned to original vendor. Goods must be in re-sellable condition, in the opinion of R&G. All returns are subject to a 25% restocking and handling fee (25% of the gross value exc. P&P – at the prevailing price at time of purchase). The customer must pay any and all carriage charges. No returns of discontinued products, unless within 14 days of purchase. This policy does not affect your statutory rights and does not refer to faulty goods.



NOTICE DE MONTAGE POUR EH0130BKA SUPPORT D'ÉCHAPPEMENT



CE KIT CONTIENT LES ARTICLES ILLUSTRÉS ET ÉTIQUETES SUR LA PAGE.

CERTAINES PARTIES PEUVENT ÊTRE PRÉSENTES UNIQUEMENT POUR LA CLARTE DES INSTRUCTIONS.

NE PAS PROCÉDER AU MONTAGE TANT QUE VOUS N'ÊTES PAS SÛR QUE TOUTES LES PIÈCES SOIENT PRÉSENTES.

VEUILLEZ LIRE TOUTES LES INSTRUCTIONS AVANT DE CONTINUER.

EN CAS DE DOUTE LORS DU MONTAGE DE NOS PRODUITS, CONSULTEZ UN DE NOS REVENEURS OU FAITES APPEL A UN TECHNICIEN QUALIFIÉ.

VEUILLEZ NOTER QUE LA FAÇON DONT LE KIT EST EMBALLÉ NE REPRÉSENTE PAS NECESSAIREMENT LA MANIÈRE DE LE MONTER SUR LA MOTO.

SI DES RONDELLES EN CAOUTCHOUC SONT UTILISÉES POUR MAINTENIR LES COMPOSANTS SUR LES BOULONS, ELLES PEUVENT ÊTRE JETÉES.

NOTICE DISPONIBLE AU TÉLÉCHARGEMENT SUR :
WWW.RG-RACING.COM



<u>OUTILS REQUIS</u>	<u>VALEURS DE SERRAGE</u>
<ul style="list-style-type: none"> • Clés Allen • Clés à molette • Clé dynamométrique 	M4 BOULON = 8Nm M5 BOULON = 12Nm M6 BOULON = 15Nm M8 BOULON = 20Nm M10 BOULON = 40Nm M12 BOULON = 40Nm

LÉGENDE

ARTICLE No	DESCRIPTION	QTÉ
ARTICLE 1	SUPPORT ÉCHAPPEMENT (HB0130)	1
ARTICLE 2	M8 x 1.25 x 15mm BOULON	2
ARTICLE 3	M8 x 1.25 x 20mm BOULON	2
ARTICLE 4	M8 x 1.25 x 25mm BOULON	1
ARTICLE 5	M8 RONDELLES	4
ARTICLE 6	M8 ÉCROU	1
ARTICLE 7	RONDELLE	2

SCHÉMA D'ENSEMBLE

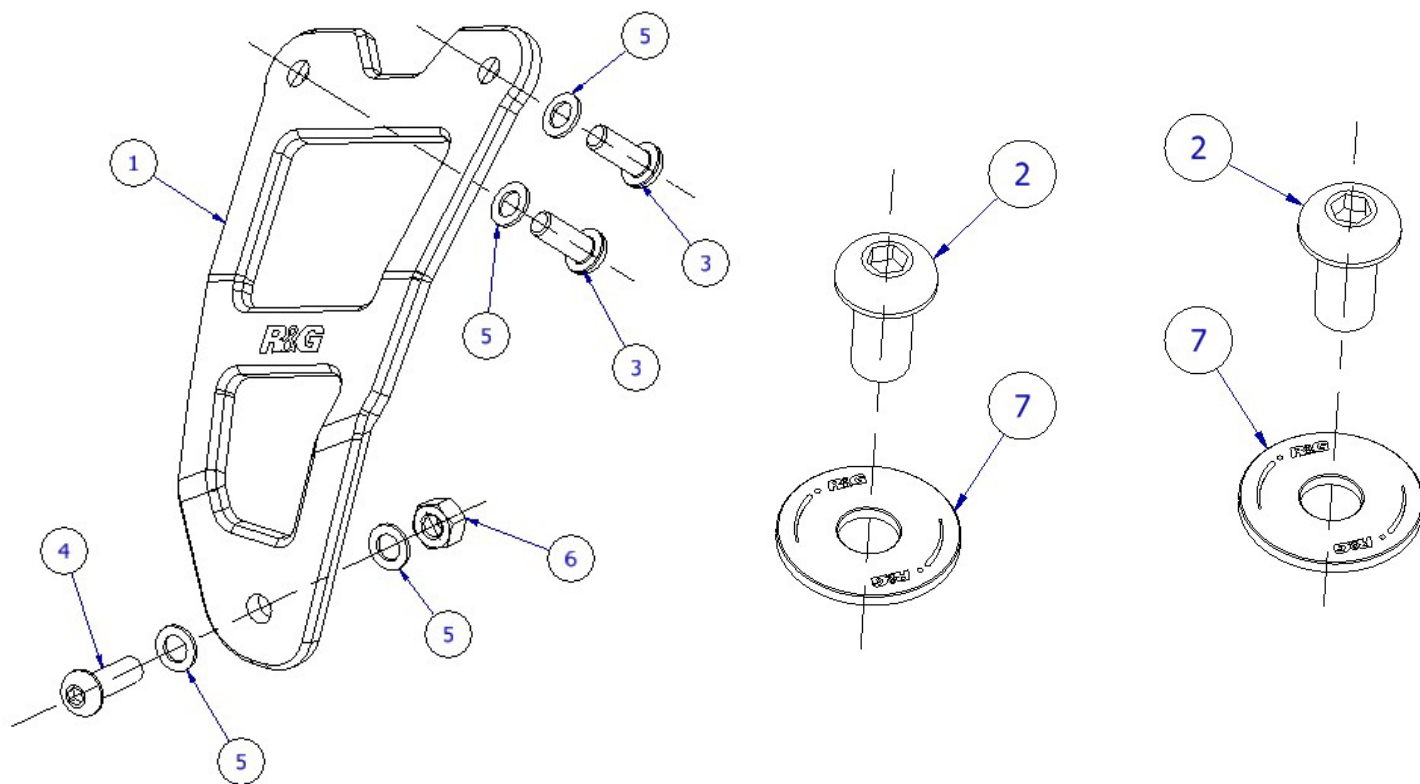

NOTICE DE MONTAGE

RETIRER AVANT LE MONTAGE

- Boulon de fixation du pot d'échappement
- Support de repose-pied passager côté gauche et droit

SUPPORT ÉCHAPPEMENT CÔTÉ DROIT

5. Une fois tous les composants retirés, placez le nouveau support d'échappement sur les trous de fixation, puis vissez les deux boulons M8 de 20 mm (ARTICLE 3) et leur rondelle (ARTICLE 5) sur chaque boulon, puis serrez. COMME INDIQUÉ SUR LE SCHÉMA DE MONTAGE.
6. Assurez-vous que le trou de fixation d'origine de l'échappement se trouve à l'intérieur du nouveau support.
7. Insérez le boulon de 25 mm (ARTICLE 4) et sa rondelle (ARTICLE 5) à travers l'extérieur du support et le trou d'échappement. Il peut être nécessaire de faire pivoter l'échappement pour aligner les trous.
8. Enfin, placez la dernière rondelle (ARTICLE 5) et l'écrou (ARTICLE 6) sur le boulon à l'arrière puis serrez.

SUPPORT ÉCHAPPEMENT CÔTÉ DROIT

4. Insérez les deux boulons de 15 mm (ARTICLE 2) dans les deux rondelles marquées (ARTICLE 7).
5. Insérez ensuite les deux vis dans les deux trous ouverts où se trouvait le support de repose-pied arrière gauche.



6. Assurez-vous de serrer tous les boulons en utilisant les réglages de couple généraux à la page 2.

Veillez noter qu'il est de votre responsabilité de vous assurer qu'aucune partie du support d'échappement ou de l'ensemble d'échappement n'entre en contact avec d'autres pièces de la machine. Ne conduisez pas la moto tant que cet aspect n'a pas été vérifié et que vous n'avez pas comprimé la suspension arrière (si cela convient à la conception de la moto) pour le tester à fond.

Issue 1 - 14/03/2025 (JH)

CONSUMER NOTICE

The catalogue description and any exhibition of samples are only broad indications of the Products and R&G may make design changes which do not diminish their performance or visual appeal and supplying them in such state shall conform to the order. The Buyer acknowledges no representation or warranty (other than as to title) has been given or will apply to the Products other than those in R&G's order or confirmation and the Buyer confirms it has chosen the Products as being of merchantable quality and suitable for its particular purposes. Where R&G fits the Products or undertakes other services it shall exercise reasonable skill and care and rectify any fault free of charge unless the workmanship has been disturbed. The Buyer is responsible for ensuring that the warranty on the motorcycle is not affected by the fitting of the Products. On return of any defective Products R&G shall at its option either supply a replacement or refund the purchase money but shall not be liable if the Products have been modified or used or maintained otherwise than in accordance with R&G's or manufacturer's instructions and good engineering practice or if the defect arises from accident or neglect. Other than identified above and subject to R&G not limiting its liability for causing death and personal injury, it shall not be liable for indirect or consequential loss and otherwise its liability shall be limited to the amounts paid by the Buyer for the Products or the fitting or service concerned. These terms do not affect the Buyer's statutory rights.

R&G RETURNS POLICY (NON-FAULTY GOODS)

Returns must be pre-authorized (if not pre-authorized the return will be rejected). Goods may only be returned direct to us if they were purchased direct from us (customer must prove if necessary). Otherwise to be returned to original vendor. Goods must be in re-sellable condition, in the opinion of R&G. All returns are subject to a 25% restocking and handling fee (25% of the gross value exc. P&P – at the prevailing price at time of purchase). The customer must pay any and all carriage charges. No returns of discontinued products, unless within 14 days of purchase. This policy does not affect your statutory rights and does not refer to faulty goods.