



**FITTING INSTRUCTIONS FOR FI0155BK LHS FRAME INSERT
BMW S1000RR 2019-**



THIS KIT CONTAINS THE ITEMS PICTURED AND LABELLED OVER PAGE.

SOME PARTS MAY BE SHOWN FOR CLARITY OF INSTRUCTIONS ONLY.

DO NOT PROCEED UNTIL YOU ARE SURE ALL PARTS ARE PRESENT.

PLEASE READ ALL INSTRUCTIONS BEFORE PROCEEDING.

**IF IN ANY DOUBT WHEN FITTING OUR PRODUCTS, CONSULT ONE OF OUR DEALERS
OR HAVE FITTED BY A QUALIFIED TECHNICIAN.**

PLEASE NOTE THAT THE WAY THE KIT IS PACKED DOES NOT NECESSARILY REPRESENT THE WAY OF
MOUNTING TO THE BIKE.

IN THE EVENT OF RUBBER WASHERS BEING USED TO HOLD COMPONENTS ONTO BOLTS,
THESE RUBBER WASHERS CAN BE THROWN AWAY.

DIGITAL COPIES OF THESE INSTRUCTIONS ARE AVAILABLE FROM:

WWW.RG-RACING.COM

R&G Racing

Unit 1, Shelleys Lane, East Worldham, Alton, Hampshire GU34 3AQ.



<u>TOOLS REQUIRED</u>	<u>GENERAL TORQUE SETTINGS</u>
<ul style="list-style-type: none"> 3mm A/F Allen Tool 	<p>M4 BOLT = 8Nm M5 BOLT = 12Nm M6 BOLT = 15Nm M8 BOLT = 20Nm M10 BOLT = 40Nm M12 BOLT = 40Nm</p>

LEGEND

ITEM No.	DESCRIPTION	QTY
ITEM 1	FI0155 FRAME INSERT LHS	1
ITEM 2	H0035 SPECIAL NUT	1
ITEM 3	M5 x 30mm COUNTERSUNK BOLT	1

EXPLODED ASSEMBLY DIAGRAM

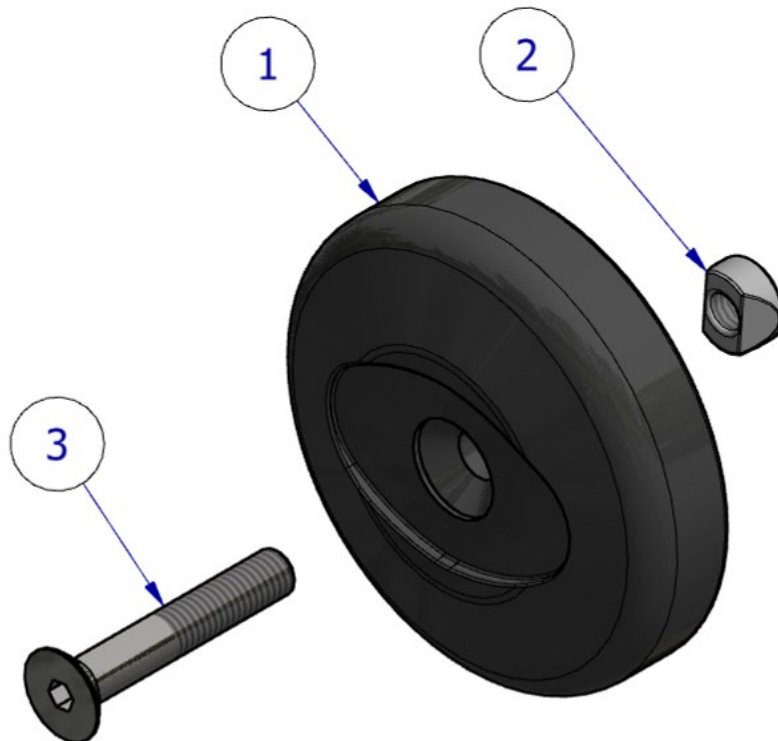



FITTING INSTRUCTIONS

- Insert the M5 x 30 countersunk bolt (item 3) through the frame insert (item 1), so the head sits within the countersunk hole.
- Place the special nut (item 2) on the exposed end of the bolt with the tapered sides facing towards the frame insert and tighten until the nut just contacts the expanding part of the frame insert.
- Place the assembly into the frame recess in the LHS of the motorcycle.
- Using a 3mm Allen tool, tighten the bolt so the frame insert is held in position firmly (do not over tighten).
- Place one supplied R&G bubble sticker into the frame insert recess to cover the head of the bolt.
- Regularly check to ensure frame insert remains tight.

ISSUE 1 - 30/10/2019 (DM)

CONSUMER NOTICE

The catalogue description and any exhibition of samples are only broad indications of the Products and R&G may make design changes which do not diminish their performance or visual appeal and supplying them in such state shall conform to the order. The Buyer acknowledges no representation or warranty (other than as to title) has been given or will apply to the Products other than those in R&G's order or confirmation and the Buyer confirms it has chosen the Products as being of merchantable quality and suitable for its particular purposes. Where R&G fits the Products or undertakes other services it shall exercise reasonable skill and care and rectify any fault free of charge unless the workmanship has been disturbed. The Buyer is responsible for ensuring that the warranty on the motorcycle is not affected by the fitting of the Products. On return of any defective Products R&G shall at its option either supply a replacement or refund the purchase money but shall not be liable if the Products have been modified or used or maintained otherwise than in accordance with R&G's or manufacturer's instructions and good engineering practice or if the defect arises from accident or neglect. Other than identified above and subject to R&G not limiting its liability for causing death and personal injury, it shall not be liable for indirect or consequential loss and otherwise its liability shall be limited to the amounts paid by the Buyer for the Products or the fitting or service concerned. These terms do not affect the Buyer's statutory rights.

R&G RETURNS POLICY (NON-FAULTY GOODS)

Returns must be pre-authorized (if not pre-authorized the return will be rejected). Goods may only be returned direct to us if they were purchased direct from us (customer must prove if necessary). Otherwise to be returned to original vendor. Goods must be in re-sellable condition, in the opinion of R&G. All returns are subject to a 25% restocking and handling fee (25% of the gross value exc. P&P – at the prevailing price at time of purchase). The customer must pay any and all carriage charges. No returns of discontinued products, unless within 14 days of purchase. This policy does not affect your statutory rights and does not refer to faulty goods.

R&G Racing

Unit 1, Shelleys Lane, East Worldham, Alton, Hampshire GU34 3AQ.



NOTICE DE MONTAGE POUR FI0155BK INSERT CADRE COTE GAUCHE BMW S1000RR 2019-



LE KIT CONTIENT LES ARTICLES EN PHOTO ET ETIQUETTES SUR LA PAGE

LES PARTIES PRESENTÉES PEUVENT ETRE UNIQUEMENT REPRESENTATIVES POUR LA CLARTE DES INSTRUCTIONS.

NE PAS PROCÉDER AU MONTAGE AVANT DE VOUS ÊTRES ASSURE QUE TOUTES LES PIECES SOIENT PRÉSENTES.

SVP, LIRE L'ENSEMBLE DE LA NOTICE AVANT DE PROCÉDER AU MONTAGE.

**EN CAS DE DOUTE LORS DU MONTAGE, CONSULTEZ UN DE NOS REVENDEURS, OU
FAITES EFFECTUER LE MONTAGE PAR UN TECHNICIEN QUALIFIE.**

VEUILLEZ NOTER QUE LA FAÇON DONT LE KIT EST EMBALLÉ NE REPRÉSENTE PAS
NÉCESSAIREMENT LA FAÇON DONT IL DOIT ETRE INSTALLE SUR LA MOTO.

NOTEZ QUE SI LES KITS SONT EMBALLÉS AVEC DES RONDELLES EN CAOUTCHOUC SERVANT À TENIR
LES COMPOSANTS, CES RONDELLES DOIVENT ÊTRE JETÉES.

NOTICE DISPONIBLE AU TÉLÉCHARGEMENT SUR :

WWW.RG-RACING.COM

R&G Racing

Unit 1, Shelleys Lane, East Worldham, Alton, Hampshire GU34 3AQ.



<u>OUTILS REQUIS</u>	<u>VALEURS DE SERRAGE</u>
<ul style="list-style-type: none"> Clés Allen 3mm 	M4 BOULON = 8NM M5 BOULON = 12NM M6 BOULON = 15NM M8 BOULON = 20NM M10 BOULON = 40NM M12 BOULON = 40NM

LEGENDE

ARTICLE No.	DESCRIPTION	QTE
ARTICLE 1	FI0155 INSERT CADRE COTE GAUCHE	1
ARTICLE 2	H0035 ECROU SPECIAL	1
ARTICLE 3	M5 x 30mm BOULON	1

SCHEMA DE MONTAGE

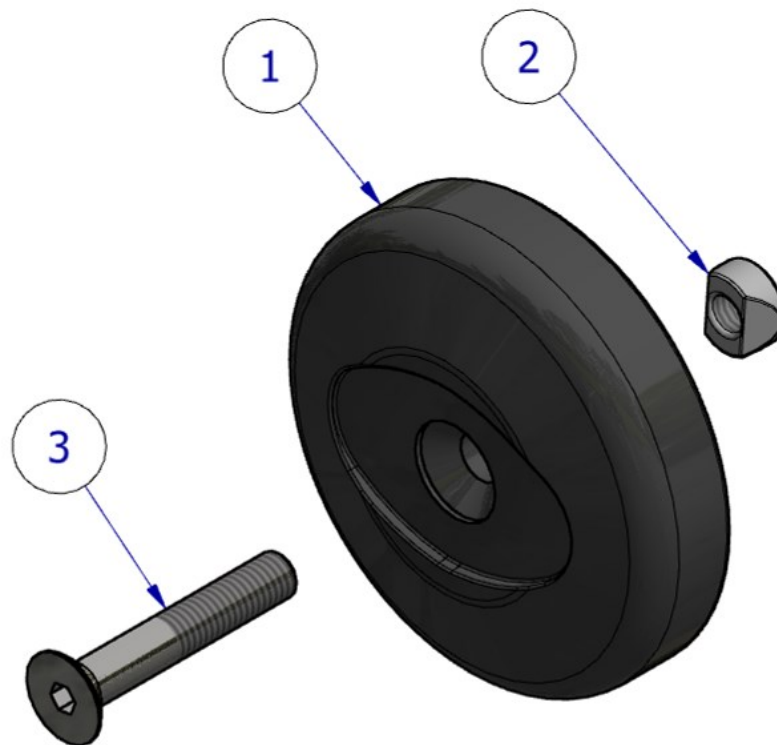

R&G Racing

Unit 1, Shelleys Lane, East Worldham, Alton, Hampshire GU34 3AQ.



NOTICE DE MONTAGE

- Insérez le boulon à tête fraisée M5 x 30 (article 3) à travers l'insert du cadre (article 1), de sorte que la tête se trouve dans le trou fraisé.
- Placer l'écrou spécial (article 2) sur l'extrémité exposée du boulon avec les côtés effilés orientés vers l'insert de cadre et serrer jusqu'à ce que l'écrou touche juste la partie dépassant de l'insert de cadre.
- Placer l'ensemble dans l'encoche du cadre du côté gauche de la moto.
- À l'aide d'une clé Allen de 3 mm, serrez le boulon de manière à ce que l'insert du cadre soit maintenu en position (ne serrez pas trop).
- Placer un sticker R&G fourni dans l'encoche d'insert de cadre pour couvrir la tête du boulon.
- Vérifiez régulièrement le serrage de l'insert du cadre.

ISSUE 1 - 30/10/2019 (DM)

R&G Racing

Unit 1, Shelleys Lane, East Worldham, Alton, Hampshire GU34 3AQ.



MONTAGEANLEITUNG FÜR FI0155BK RAHMENEINSATZ—LINKE SEITE BMW S1000RR 2019-



ALLE KIT-TEILE SIND UNTEN ABGEBILDET UND GEKENNZEICHNET

DIE ABGEBILDETEN TEILE DIENEN LEDIGLICH ZUR ERKLÄRUNG.

ÜBERPRÜFEN SIE, DASS ALLE TEILE VORHANDEN SIND, BEVOR SIE MIT DER MONTAGE BEGINNEN.

LESEN SIE DIE MONTAGEANLEITUNG KOMPLETT DURCH, BEVOR SIE ANFANGEN.

WENN SIE UNSICHER SIND BEI DER MONTAGE DIESES PRODUKTES, BITTE EINEN UNSERER HÄNDLER KONTAKTIEREN ODER DAS KIT VON EINEM QUALIFIZIERTEN ZWEIRAD-MECHANIKER MONTIEREN LASSEN.

Die Verpackung der Teile stellt nicht die Reihenfolge der Montage dar.

Hinweis für Kits mit Plastikunterlegscheiben an den Schrauben – Diese Plastik-Unterlegscheiben werden nicht für den Einbau benötigt!

EINE DIGITALE VERSION DIESER MONTAGEANLEITUNG KANN AUF FOLGENDER SEITE HERUNTERGELADEN WERDEN:

www.rg-racing.com

R&G Racing

Unit 1, Shelleys Lane, East Worldham, Alton, Hampshire GU34 3AQ.



<u>SIE BENÖTIGEN FOLGENDES WERKZEUG</u>	<u>ALLGEM. ANZUGSDREHMOMENT</u>
<ul style="list-style-type: none"> 3mm A/F Inbusschlüssel 	M4 SCHRAUBE = 8Nm M5 SCHRAUBE = 12Nm M6 SCHRAUBE = 15Nm M8 SCHRAUBE = 20Nm M10 SCHRAUBE = 40Nm M12 SCHRAUBE = 40Nm

LIEFERUMFANG

ARTIKEL Nr.	BESCHREIBUNG	MENGE
ARTIKEL 1	FI0155 RAHMENEINSATZ LINKE SEITE	1
ARTIKEL 2	H0035 SPEZIALMUTTER	1
ARTIKEL 3	M5 x 30mm SENKSCHRAUBE	1

EXPLOSIONSZEICHNUNG ZUSAMMENBAU

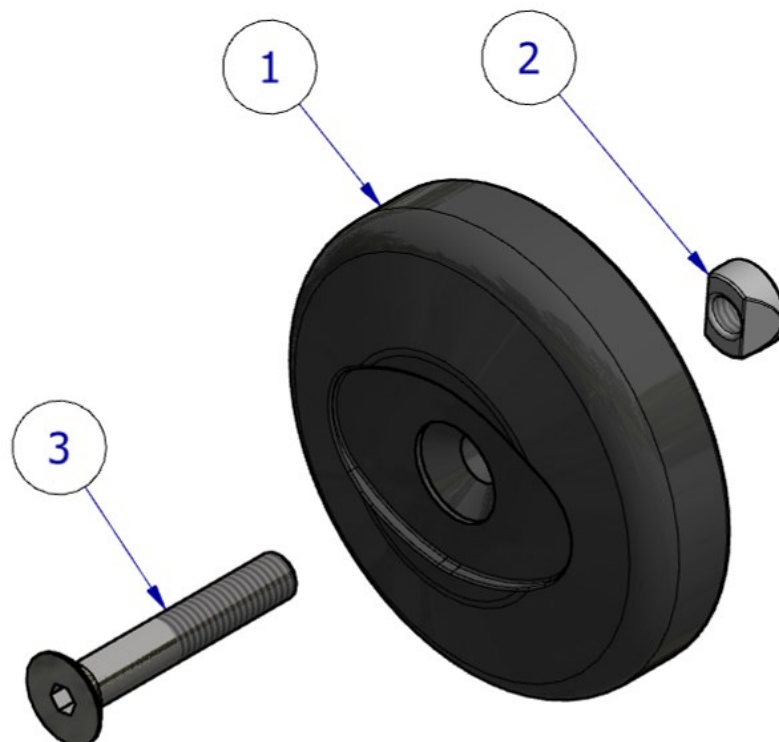

R&G Racing

Unit 1, Shelleys Lane, East Worldham, Alton, Hampshire GU34 3AQ.



MONTAGEANLEITUNG

- Die M5 x 30 Senkschraube (Artikel 3) in den Rahmeneinsatz (Artikel 1) einsetzen, sodass der Schraubenkopf in die Gegenbohrung passt.
- Die Spezialmutter (Artikel 2) am hervorstehenden Ende der Schraube anbringen, sodass die konische Flächen mit dem Rahmeneinsatz ausgerichtet sind und anziehen bis die Mutter das expandierende Teil des Rahmeneinsatzes leicht berührt.
- Die Einheit in die Rahmenvertiefung an der linken Seite des Motorrades einsetzen.
- Ziehen Sie die Schraube mit einem 3mm Inbusschlüssel fest, sodass der Rahmeneinsatz sicher in Position befestigt ist (nicht überziehen).
- Einen R&G Bubble-Aufkleber vom Kit in der Vertiefung des Rahmeneinsatzes montieren, um den Schraubenkopf abzudecken.
- Überprüfen Sie regelmäßig, dass der Rahmeneinsatz fest fixiert ist.

AUSGABE 1 - 30/10/2019 (DM)

R&G Racing

Unit 1, Shelleys Lane, East Worldham, Alton, Hampshire GU34 3AQ.