



**FITTING INSTRUCTIONS FOR LP0314**  
**LICENSE PLATE BRACKET**  
**HONDA NC750X 2021-**



**THIS KIT CONTAINS THE ITEMS PICTURED AND LABELLED OVER PAGE.**

SOME PARTS MAY BE SHOWN FOR CLARITY OF INSTRUCTIONS ONLY.

DO NOT PROCEED UNTIL YOU ARE SURE ALL PARTS ARE PRESENT.

**PLEASE READ ALL INSTRUCTIONS BEFORE PROCEEDING.**

**IF IN ANY DOUBT WHEN FITTING OUR PRODUCTS, CONSULT ONE OF OUR DEALERS  
OR HAVE FITTED BY A QUALIFIED TECHNICIAN.**

PLEASE NOTE THAT THE WAY THE KIT IS PACKED DOES NOT NECESSARILY REPRESENT THE WAY OF  
MOUNTING TO THE BIKE.

IN THE EVENT OF RUBBER WASHERS BEING USED TO HOLD COMPONENTS ONTO BOLTS,  
THESE RUBBER WASHERS CAN BE THROWN AWAY.

**DIGITAL COPIES OF THESE INSTRUCTIONS ARE AVAILABLE FROM:**

**[WWW.RG-RACING.COM](http://WWW.RG-RACING.COM)**

R&G Racing  
Unit 1, Shelley's Lane, East Worldham, Alton, Hampshire, GU34 3AQ  
Tel: +44 (0)1420 89007 Fax: +44 (0)1420 87301 [www.rg-racing.com](http://www.rg-racing.com) Email: [info@rg-racing.com](mailto:info@rg-racing.com)



<b><u>TOOLS REQUIRED</u></b>	<b><u>GENERAL TORQUE SETTINGS</u></b>
<ul style="list-style-type: none"> <li>• 6, 8, 10 &amp; 12mm SPANNERS OR SOCKETS</li> <li>• ALLEN KEY SET</li> <li>• SMALL FLAT HEAD SCREWDRIVER</li> </ul>	<p>M4 BOLT = 8Nm</p> <p>M5 BOLT = 12Nm</p> <p>M6 BOLT = 15Nm</p> <p>M8 BOLT = 20Nm</p> <p>M10 BOLT = 40Nm</p> <p>M12 BOLT = 40Nm</p>

### **LEGEND**

<b>ITEM NO.</b>	<b>DESCRIPTION</b>	<b>QTY</b>
ITEM 1	TB0314 LICENSE PLATE BRACKET	1
ITEM 2	S1352 REAR SPACER	2
ITEM 3	S1353 FRONT SPACER	2
ITEM 4	M6x20mm CAP HEAD BOLT	2
ITEM 5	M6x25mm CAP HEAD BOLT	2
ITEM 6	M6 PENNY WASHERS	4
ITEM 7	M6 NYLOC NUTS	4
ITEM 8	CON009 INDICATOR CONNECTOR	2
ITEM 9	CON049 ILLUMINATOR CONNECTOR	1
ITEM 10	CT75 75mm LONG CABLE TIE	6
ITEM 11	666-896 150mm LENGTH OF HEAT SHRINK	3
ITEM 12	CLIP1 SELF ADHEISIVE CABLE CLIP	3
ITEM 13	REFL1 REFLECTOR	1
ITEM 14	I0049 MINI INDICATOR ADAPTORS	4
ITEM 15	I0050 OEM INDICATOR ADAPTORS	2
ITEM 16	LA0002 PLATE LIGHT ASSEMBLY	1

R&G Racing

Unit 1, Shelley's Lane, East Worldham, Alton, Hampshire, GU34 3AQ

Tel: +44 (0)1420 89007 Fax: +44 (0)1420 87301 [www.rg-racing.com](http://www.rg-racing.com) Email: [info@rg-racing.com](mailto:info@rg-racing.com)

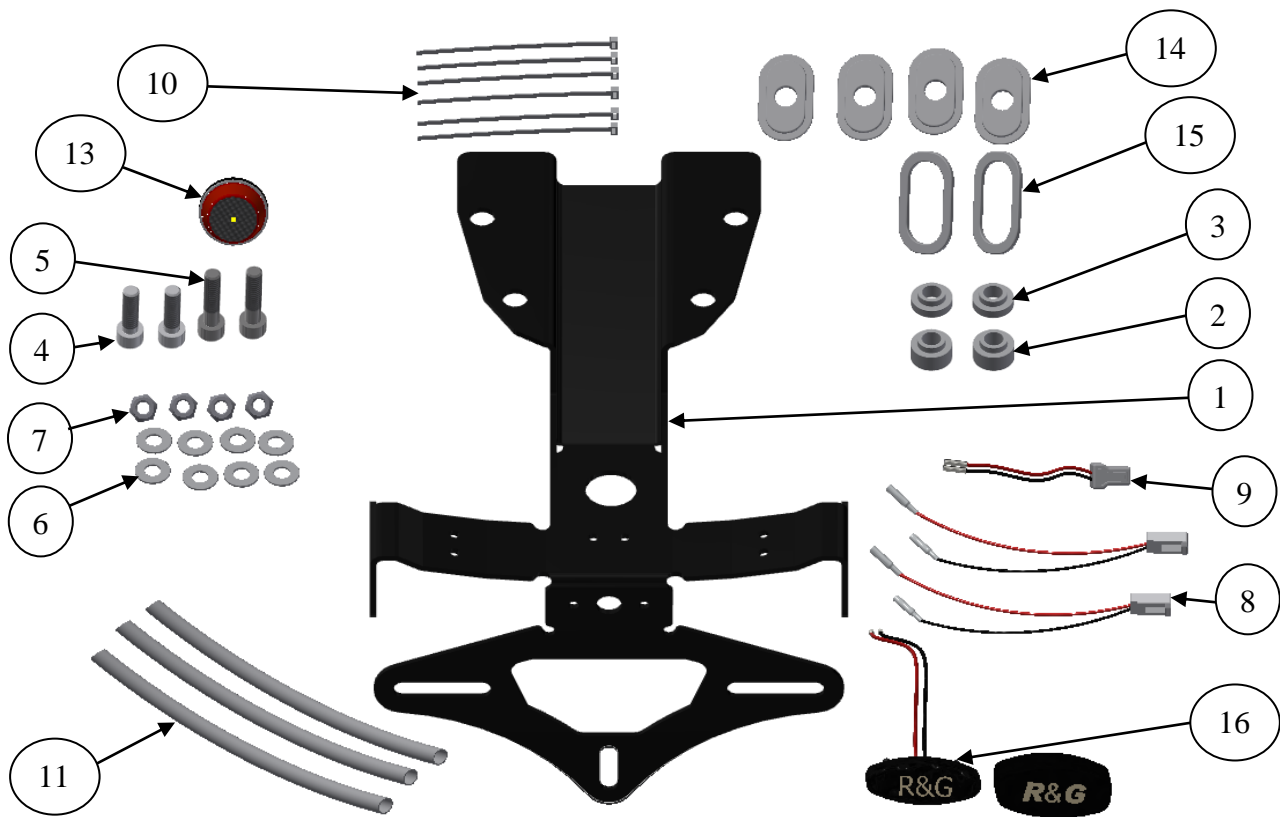

**FITTING PICTURES**

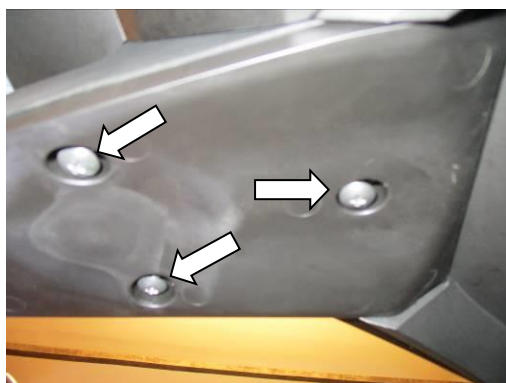

Picture 1



Picture 2



**Picture 3**

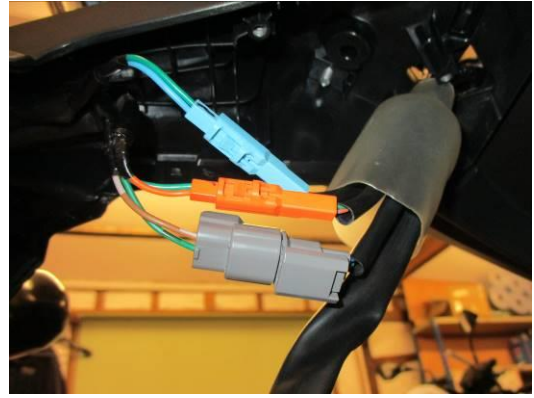

**Picture 4**



**Picture 5**



**Picture 6**

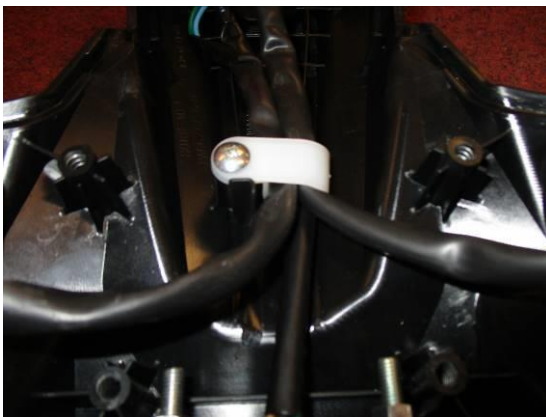

**Picture 7**



**Picture 8**





Picture 9



Picture 10



Picture 11



Picture 12



Picture 13



Picture 14

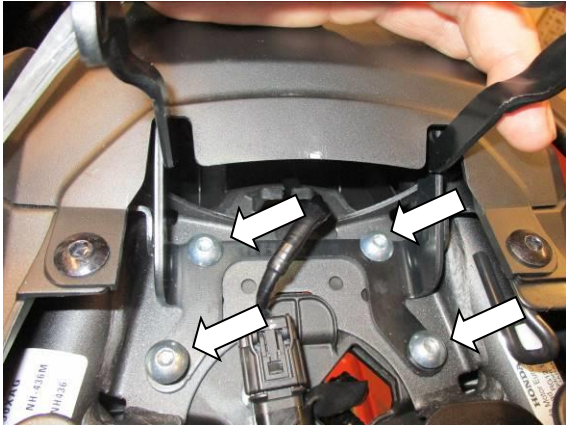

Picture 15



Picture 16

### **FITTING INSTRUCTIONS**

- Remove the seat.
- Remove the seven screws arrowed in pictures 1 and 2.
- Unclip and remove the cable cover to allow access to the wiring plug sockets.
- Unclip the cable tidy arrowed in picture 3.
- Disconnect the indicator and licence plate illuminator plug sockets arrowed in picture 4 (*It's a good idea to mark the matching connectors up at this stage to make re-fitting easier*).
- Remove the four bolts arrowed in picture 5.
- Carefully lower the original licence plate bracket while feeding the wiring through the hole in the original licence plate bracket as shown in picture 6.
- Feed the wiring through the hole in the under-tray so the wiring is in the under-seat compartment.

#### **If reusing the original indicators:**

- Remove the cable tidy clamp arrowed in picture 7.
- Remove the bolt arrowed in picture 8 and remove the indicator as shown in picture 9.
- Remove the indicator clamp bracket as shown in picture 10.
- Remove the indicator rubber as shown in picture 11.
- Repeat the above steps for the opposite indicator.
- Place the indicator spacers (item 3) onto the original indicator rubber as shown below.



- Fit the original indicators to the new licence plate bracket (item 1) as shown in picture 12 and secure as original.

#### **If using the mini indicators:**

- To fit the R&G Mini indicators, fit one length of heat-shrink (item 11) to the wires of each indicator.



- Position two indicator adaptors (item 14) onto the wiring of each indicator, ensuring the sides facing each other have the raised centre profile, before fitting the flanged nut supplied, as shown below.



- Fit the R&G licence plate illuminator (item 16) as shown in pictures 13 and 14.
- Use the supplied cable ties and cable clips to tidy and hold the wiring in place.
- Place the tail tidy assembly on the rear wheel whilst the wiring is placed through the hole on the underside of the rear sub-frame.
- Offer the tail tidy assembly up to the underside of the tail unit (as shown in the top pictures) and place one of the M6 x 25mm Button Head Bolts (item 5) with a washer (item 6) through the licence plate bracket from the underside, and into the location point within the rear sub-frame, as shown in picture 15. With the exposed thread of the bolt protruding from above, place an M6 Nyloc Nut (item 7) onto the bolt and loosely tighten.
- Fit the three remaining bolts with washers through the licence plate bracket in the same way, and loosely tighten the Nyloc nuts.
- With all four bolts in place, these can be tightened. *Please ensure the wires are not trapped.*
- Connect the licence plate illuminator using the supplied plug socket (if the licence plate illuminator fails to light please swap the bullet connectors over), if using original indicators, connect to the main loom on the bike as original (they are colour coded to avoid confusion) and check the operation of the indicators and lights. If using R&G mini indicators please use the two remaining connectors (item 8) to connect to the main loom. If using R&G LED type indicators, resistors (R&G product code RGR0001) may have to be used to achieve the correct flash rate (if illumination fails please swap the bullet connectors over).
- Refit the seat unit and licence plate.
- Depending on local laws, attach enclosed reflector (item 13) in an appropriate location.
- **Please test the indicators, rear light and licence plate illuminator before riding.**

#### **IMPORTANT:**

IF FITTING A FULL-SIZE LICENCE PLATE AND PLACING IT FAR DOWN ON THE LICENCE PLATE HANGER, THERE IS A SMALL CHANCE OF THE LICENCE PLATE HITTING THE BACK WHEEL UNDER HEAVY LOAD AND OVER LARGE BUMPS IN THE ROAD. IT IS YOUR RESPONSIBILITY TO CHECK FOR THIS POSSIBILITY AND TAKE AVOIDING ACTION. FAILURE TO CHECK THIS COULD RESULT IN SERIOUS INJURY.

ISSUE 1 - 13/09/2021 (WW)

#### **CONSUMER NOTICE**

The catalogue description and any exhibition of samples are only broad indications of the Products and R&G may make design changes which do not diminish their performance or visual appeal and supplying them in such state shall conform to the order. The Buyer acknowledges no representation or warranty (other than as to title) has been given or will apply to the Products other than those in R&G's order or confirmation and the Buyer confirms it has chosen the Products as being of merchantable quality and suitable for its particular purposes. Where R&G fits the Products or undertakes other services it shall exercise reasonable skill and care and rectify any fault free of charge unless the workmanship has been disturbed. The Buyer is responsible for ensuring that the warranty on

R&G Racing

Unit 1, Shelley's Lane, East Worldham, Alton, Hampshire, GU34 3AQ

Tel: +44 (0)1420 89007 Fax: +44 (0)1420 87301 [www.rg-racing.com](http://www.rg-racing.com) Email: [info@rg-racing.com](mailto:info@rg-racing.com)





the motorcycle is not affected by the fitting of the Products. On return of any defective Products R&G shall at its option either supply a replacement or refund the purchase money but shall not be liable if the Products have been modified or used or maintained otherwise than in accordance with R&G's or manufacturer's instructions and good engineering practice or if the defect arises from accident or neglect. Other than identified above and subject to R&G not limiting its liability for causing death and personal injury, it shall not be liable for indirect or consequential loss and otherwise its liability shall be limited to the amounts paid by the Buyer for the Products or the fitting or service concerned. These terms do not affect the Buyer's statutory rights.

**R&G RACING RETURNS POLICY (NON-FAULTY GOODS)**

Returns must be pre-authorized (if not pre-authorized the return will be rejected). Goods may only be returned direct to us if they were purchased direct from us (customer must prove if necessary). Otherwise to be returned to original vendor. Goods must be in re-sellable condition, in the opinion of R&G Racing. All returns are subject to a 25% restocking and handling fee (25% of the gross value exc. P&P – at the prevailing price at time of purchase). The customer must pay any and all carriage charges. No returns of discontinued products, unless within 14 days of purchase. This policy does not affect your statutory rights and does not refer to faulty goods.

R&G Racing

Unit 1, Shelley's Lane, East Worldham, Alton, Hampshire, GU34 3AQ

Tel: +44 (0)1420 89007 Fax: +44 (0)1420 87301 [www.rg-racing.com](http://www.rg-racing.com) Email: [info@rg-racing.com](mailto:info@rg-racing.com)





**NOTICE DE MONTAGE POUR LP0314**  
**SUPPORT DE PLAQUE**  
**HONDA NC750X 2021-**



**CE KIT CONTIENT LES ARTICLES ILLUSTRÉS ET ÉTIQUETES SUR LA PAGE.**

CERTAINES PARTIES PEUVENT ÊTRE PRÉSENTES UNIQUEMENT POUR LA CLARTÉ DES INSTRUCTIONS.

NE PAS PROCÉDER AU MONTAGE TANT QUE VOUS N'ÊTES PAS SÛR QUE TOUTES LES PIÈCES SOIENT PRÉSENTES.

**VEUILLEZ LIRE TOUTES LES INSTRUCTIONS AVANT DE CONTINUER.**

**EN CAS DE DOUTE LORS DU MONTAGE DE NOS PRODUITS, CONSULTEZ UN DE NOS REVENEURS OU FAITES APPEL A UN TECHNICIEN QUALIFIÉ.**

VEUILLEZ NOTER QUE LA FAÇON DONT LE KIT EST EMBALLÉ NE REPRÉSENTE PAS NECESSAIREMENT LA MANIÈRE DE LE MONTER SUR LA MOTO.

SI DES RONDELLES EN CAOUTCHOUC SONT UTILISÉES POUR MAINTENIR LES COMPOSANTS SUR LES BOULONS, ELLES PEUVENT ÊTRE JETÉES.

**NOTICE DISPONIBLE AU TÉLÉCHARGEMENT SUR :**

[WWW.RG-RACING.COM](http://WWW.RG-RACING.COM)

R&G Racing

Unit 1, Shelley's Lane, East Worldham, Alton, Hampshire, GU34 3AQ

Tel: +44 (0)1420 89007 Fax: +44 (0)1420 87301 [www.rg-racing.com](http://www.rg-racing.com) Email: [info@rg-racing.com](mailto:info@rg-racing.com)



<b><u>OUTILS REQUIS</u></b>	<b><u>VALEURS DE SERRAGE</u></b>
<ul style="list-style-type: none"> <li>• CLÉ À MOLETTE 6, 8, 10 &amp; 12mm</li> <li>• CLÉ ALLEN</li> <li>• PETIT TOURNEVIS PLAT</li> </ul>	M4 BOULON = 8Nm M5 BOULON = 12Nm M6 BOULON = 15Nm M8 BOULON = 20Nm M10 BOULON = 40Nm M12 BOULON = 40Nm

### **LÉGENDE**

<b>ARTICLE NO.</b>	<b>DESCRIPTION</b>	<b>QTÉ</b>
ARTICLE 1	TB0314 SUPPORT DE PLAQUE	1
ARTICLE 2	S1352 ENTRETOISE ARRIÈRE	2
ARTICLE 3	S1353 ENTRETOISE AVANT	2
ARTICLE 4	M6x20mm BOULON	2
ARTICLE 5	M6x25mm BOULON	2
ARTICLE 6	M6 RONDELLES	4
ARTICLE 7	M6 ÉCROUS	4
ARTICLE 8	CON009 CONNECTEUR DE CLIGNOTANT	2
ARTICLE 9	CON049 CONNECTEUR DE FEU	1
ARTICLE 10	CT75 75mm COLLIER DE SERRAGE	6
ARTICLE 11	666-896 150mm MANCHON THERMO RÉTRACTABLE	3
ARTICLE 12	CLIP1 CLIP CÂBLE AUTOCOLLANT	3
ARTICLE 13	REFL1 RÉFLECTEUR	1
ARTICLE 14	I0049 ADAPTATEURS DE MINI CLIGNOTANTS	4
ARTICLE 15	I0050 ADAPTATEURS DE CLIGNOTANTS D'ORIGINE	2
ARTICLE 16	LA0002 ASSEMBLAGE FEU DE PLAQUE	1

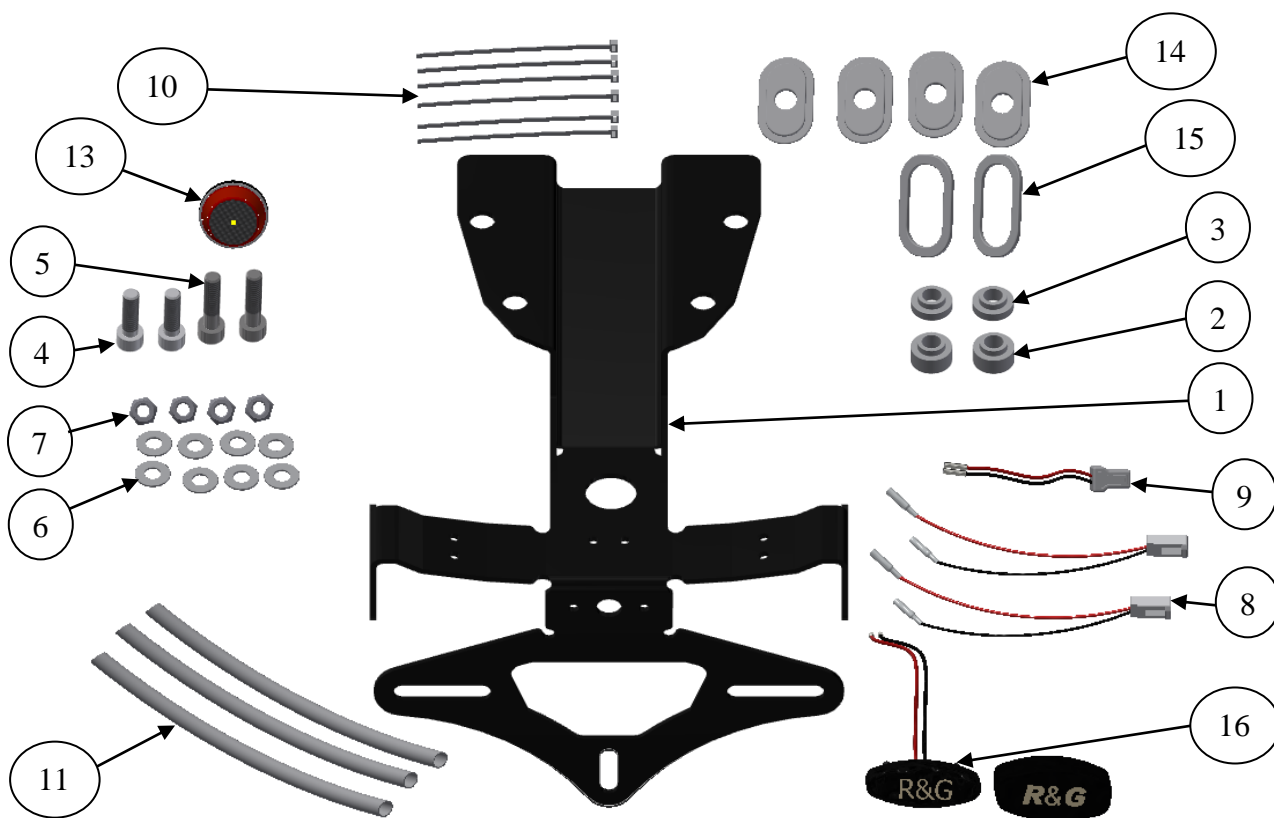

**PHOTOS DE MONTAGE**



**Photo 1**



**Photo 2**



**Photo 3**

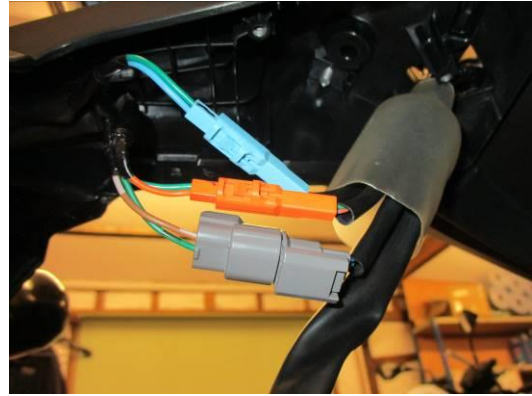

**Photo 4**



**Photo 5**



**Photo 6**

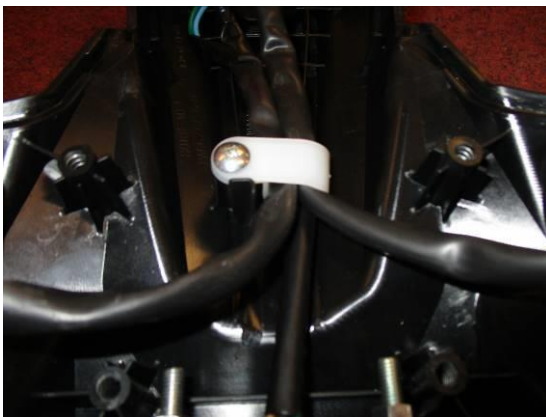

**Photo 7**



**Photo 8**





**Photo 9**



**Photo 10**



**Photo 11**



**Photo 12**



**Photo 13**



**Photo 14**

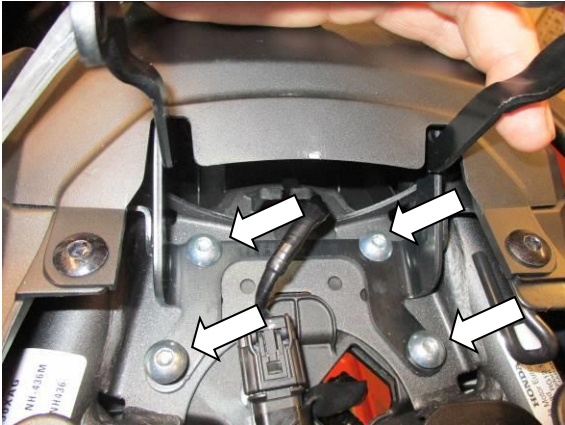

Photo 15



Photo 16

### **NOTICE DE MONTAGE**

- Déclipser et retirer le cache-câbles pour permettre l'accès aux prises de câblage.
- Déclippez le passe-câbles fléché sur la photo 3.
- Débranchez les prises fléchées du feu de clignotant et de la plaque d'immatriculation sur la photo 4 (il est judicieux de repérer à ce stade les connecteurs correspondants pour faciliter le remontage).
- Retirez les quatre boulons fléchés sur la photo 5.
- Abaissez soigneusement le support de plaque d'immatriculation d'origine tout en faisant passer le câblage à travers le trou du support de plaque d'immatriculation d'origine, comme indiqué sur la photo 6.
- Faites passer le câblage par le trou du plateau inférieur de manière à ce que le câblage se trouve dans le compartiment sous le siège.
- Retirez le siège.
- Retirez les sept vis fléchées sur les photos 1 et 2.

#### **Si vous réutilisez les clignotants d'origine :**

- Retirez le serre-câbles fléché sur la photo 7.
- Retirez le boulon fléché sur la photo 8 et retirez le clignotant comme indiqué sur la photo 9.
- Retirez le support de serrage de clignotant comme indiqué sur la photo 10.
- Retirez le caoutchouc de clignotant comme indiqué sur la photo 11.
- Répétez les étapes ci-dessus pour l'autre clignotant.
- Placer les entretoises de clignotant (article 3) sur le caoutchouc de clignotant d'origine comme indiqué ci-dessous.



- Montez les clignotants d'origine sur le nouveau support de plaque d'immatriculation (article 1) comme indiqué sur la photo 12 et fixez comme d'origine.

R&G Racing

Unit 1, Shelley's Lane, East Worldham, Alton, Hampshire, GU34 3AQ

Tel: +44 (0)1420 89007 Fax: +44 (0)1420 87301 [www.rg-racing.com](http://www.rg-racing.com) Email: [info@rg-racing.com](mailto:info@rg-racing.com)



**Si vous utilisez les mini clignotants :**

- Pour monter les mini clignotants R&G, placez une longueur de gaine thermo rétractable (article 11) sur les fils de chaque clignotant.
- Positionner deux adaptateurs de clignotants (article 14) sur le câblage de chaque clignotant, en veillant à ce que les côtés se faisant face présentent le profil central surélevé, avant de monter l'écrou à embase fourni, comme illustré ci-dessous.



- Monter le feu de plaque d'immatriculation R&G (article 16) comme indiqué sur les photos 13 et 14.
- Utilisez les attaches de câble et les serre-câbles fournis pour ranger et maintenir le câblage en place.
- Placez l'ensemble du support sur la roue arrière pendant que le câblage est placé à travers le trou sur la face inférieure du sous cadre arrière.
- Présentez l'ensemble du support au-dessous de l'unité (comme indiqué sur les photos du haut) et placez l'un des boulons à tête ronde M6 x 25 mm (article 5) avec une rondelle (article 6) à travers le support de plaque d'immatriculation au dessous et dans le point d'emplacement à l'intérieur du sous-cadre arrière, comme indiqué sur la photo 15. Avec le filetage exposé du boulon dépassant du dessus, placez un écrou Nyloc M6 (article 7) sur le boulon et serrez légèrement.
- Montez les trois boulons restants avec des rondelles à travers le support de plaque d'immatriculation de la même manière et serrez légèrement les écrous Nyloc.
- Une fois les quatre boulons en place, ceux-ci peuvent être serrés. Veuillez-vous assurer que les fils ne soient pas coincés.
- Connectez l'éclairage de plaque d'immatriculation à l'aide de la prise de courant fournie (si l'éclairage de plaque d'immatriculation ne s'allume pas, veuillez échanger les connecteurs), si vous utilisez des clignotants d'origine, connectez-vous au métier à tisser principal sur la moto comme d'origine (ils sont codés par couleur pour éviter confusion) et vérifiez le fonctionnement des clignotants et des voyants. Si vous utilisez des mini clignotants R&G, veuillez utiliser les deux connecteurs restants (article 8) pour vous connecter au métier à tisser principal. Si vous utilisez des clignotants de type LED R&G, des résistances (code de produit R&G RGR0001) devront peut-être être utilisées pour obtenir le taux de luminosité correct (si l'éclairage échoue, veuillez échanger les connecteurs).
- Reposer le siège et la plaque d'immatriculation.
- Selon les lois locales, fixez le réflecteur inclus (article 13) dans un endroit approprié.
- **Testez l'éclairage de plaque d'immatriculation et tous les feux avant de rouler.**

**IMPORTANT:**

**SI VOUS INSTALLEZ UNE PLAQUE D'IMMATRICULATION DE GRANDE TAILLE ET LA PLACEZ LOIN VERS LE BAS SUR LE SUPPORT DE PLAQUE D'IMMATRICULATION, IL Y A UNE FAIBLE CHANCE QUE LA PLAQUE D'IMMATRICULATION FRAPPE LA ROUE ARRIÈRE SOUS L'EFFET D'UNE CHARGE LOURDE ET**

R&G Racing

Unit 1, Shelley's Lane, East Worldham, Alton, Hampshire, GU34 3AQ

Tel: +44 (0)1420 89007 Fax: +44 (0)1420 87301 [www.rg-racing.com](http://www.rg-racing.com) Email: [info@rg-racing.com](mailto:info@rg-racing.com)





**SUR DE GRANDES BOSSES SUR LA ROUTE. IL EST DE VOTRE RESPONSABILITÉ DE VÉRIFIER CETTE POSSIBILITÉ ET DE PRENDRE DES MESURES POUR L'ÉVITER. NE PAS VÉRIFIER CECI POURRAIT ENTRAÎNER DES BLESSURES GRAVES.**

ISSUE 1 - 13/09/2021 (WW)

#### **CONSUMER NOTICE**

The catalogue description and any exhibition of samples are only broad indications of the Products and R&G may make design changes which do not diminish their performance or visual appeal and supplying them in such state shall conform to the order. The Buyer acknowledges no representation or warranty (other than as to title) has been given or will apply to the Products other than those in R&G's order or confirmation and the Buyer confirms it has chosen the Products as being of merchantable quality and suitable for its particular purposes. Where R&G fits the Products or undertakes other services it shall exercise reasonable skill and care and rectify any fault free of charge unless the workmanship has been disturbed. The Buyer is responsible for ensuring that the warranty on the motorcycle is not affected by the fitting of the Products. On return of any defective Products R&G shall at its option either supply a replacement or refund the purchase money but shall not be liable if the Products have been modified or used or maintained otherwise than in accordance with R&G's or manufacturer's instructions and good engineering practice or if the defect arises from accident or neglect. Other than identified above and subject to R&G not limiting its liability for causing death and personal injury, it shall not be liable for indirect or consequential loss and otherwise its liability shall be limited to the amounts paid by the Buyer for the Products or the fitting or service concerned. These terms do not affect the Buyer's statutory rights.

#### **R&G RACING RETURNS POLICY (NON-FAULTY GOODS)**

Returns must be pre-authorized (if not pre-authorized the return will be rejected). Goods may only be returned direct to us if they were purchased direct from us (customer must prove if necessary). Otherwise to be returned to original vendor. Goods must be in re-sellable condition, in the opinion of R&G Racing. All returns are subject to a 25% restocking and handling fee (25% of the gross value exc. P&P - at the prevailing price at time of purchase). The customer must pay any and all carriage charges. No returns of discontinued products, unless within 14 days of purchase. This policy does not affect your statutory rights and does not refer to faulty goods.

R&G Racing

Unit 1, Shelley's Lane, East Worldham, Alton, Hampshire, GU34 3AQ

Tel: +44 (0)1420 89007 Fax: +44 (0)1420 87301 [www.rg-racing.com](http://www.rg-racing.com) Email: [info@rg-racing.com](mailto:info@rg-racing.com)





**MONTAGEANLEITUNG FÜR LP0314**  
**KENNZEICHENHALTER**  
**HONDA NC750X 2021-**



**ALLE KIT-TEILE SIND AUF DEN NACHFOLGENDEN SEITEN ABGEBILDET UND GEKENNZEICHNET.**

DIE ABGEBILDETEN TEILE DIENEN LEDIGLICH ZUR ERKLÄRUNG.

ÜBERPRÜFEN SIE ZUERST, DASS ALLE TEILE VORHANDEN SIND.

**LESEN SIE DIE MONTAGEANLEITUNG KOMPLETT DURCH, BEVOR SIE ANFANGEN.**

**WENN SIE BEI DER MONTAGE DIESES PRODUKTES UNSICHER SIND, BITTE EINEN  
UNSERER HÄNDLER KONTAKTIEREN ODER DAS KIT VON EINEM QUALIFIZIERTEN  
ZWEIRAD-MECHANIKER MONTIEREN LASSEN.**

DIE VERPACKUNG DER TEILE STELLT NICHT DIE REIHENFOLGE DER MONTAGE DAR.

HINWEIS FÜR KITS MIT PLASTIKUNTERLEGSCHLEIBEN AN DEN SCHRAUBEN –  
DIESE PLASTIK-UNTERLEGSCHLEIBEN WERDEN NICHT FÜR DEN EINBAU BENÖTIGT.



**EINE DIGITALE VERSION DIESER MONTAGEANLEITUNG KANN AUF  
FOLGENDER SEITE HERUNTERGELADEN WERDEN:**

[WWW.RG-RACING.COM](http://WWW.RG-RACING.COM)

<b><u>SIE BENÖTIGEN FOLGENDES WERKZEUG</u></b>	<b><u>ALLGEM. ANZUGSDREHMOMENT</u></b>
<ul style="list-style-type: none"> <li>• 6, 8, 10 &amp; 12mm SCHRAUBENSCHLÜSSEL ODER STECKSCHLÜSSEL</li> <li>• SATZ INBUSSCHLÜSSEL</li> <li>• FLACHKLINGEN-SCHRAUBENZIEHER</li> </ul>	<p>M4 SCHRAUBE = 8Nm</p> <p>M5 SCHRAUBE = 12Nm</p> <p>M6 SCHRAUBE = 15Nm</p> <p>M8 SCHRAUBE = 20Nm</p> <p>M10 SCHRAUBE = 40Nm</p> <p>M12 SCHRAUBE = 40Nm</p>

**LIEFERUMFANG**

<b>ARTIKEL NR.</b>	<b>BESCHREIBUNG</b>	<b>MENGE</b>
ARTIKEL 1	TB0314 KENNZEICHENHALTER	1
ARTIKEL 2	S1352 DISTANZHALTER HINTEN	2
ARTIKEL 3	S1353 DISTANZHALTER VORNE	2
ARTIKEL 4	M6x20mm INNENSECHSKANTSCHRAUBE	2
ARTIKEL 5	M6x25mm INNENSECHSKANTSCHRAUBE	2
ARTIKEL 6	M6 UNTERLEGSCHNEIBE	4
ARTIKEL 7	M6 SELBSTSICHERNDE MUTTER	4
ARTIKEL 8	CON009 VERBINDUNG BLINKER	2
ARTIKEL 9	CON049 VERBINDUNG KENNZEICHENBELEUCHTUNG	1
ARTIKEL 10	CT75 75mm KABELBINDER	6
ARTIKEL 11	666-896 150mm SCHRUMPFSCHLAUCH	3
ARTIKEL 12	CLIP1 KABELCLIP - SELBSTKLEBEND	3
ARTIKEL 13	REFL1 RÜCKSTRAHLER	1
ARTIKEL 14	I0049 ADAPTER MINIBLINKER	4
ARTIKEL 15	I0050 ADAPTER ORIGINALBLINKER	2
ARTIKEL 16	LA0002 KENNZEICHENBELEUCHTUNG	1

R&G Racing

Unit 1, Shelley's Lane, East Worldham, Alton, Hampshire, GU34 3AQ

Tel: +44 (0)1420 89007 Fax: +44 (0)1420 87301 [www.rg-racing.com](http://www.rg-racing.com) Email: [info@rg-racing.com](mailto:info@rg-racing.com)

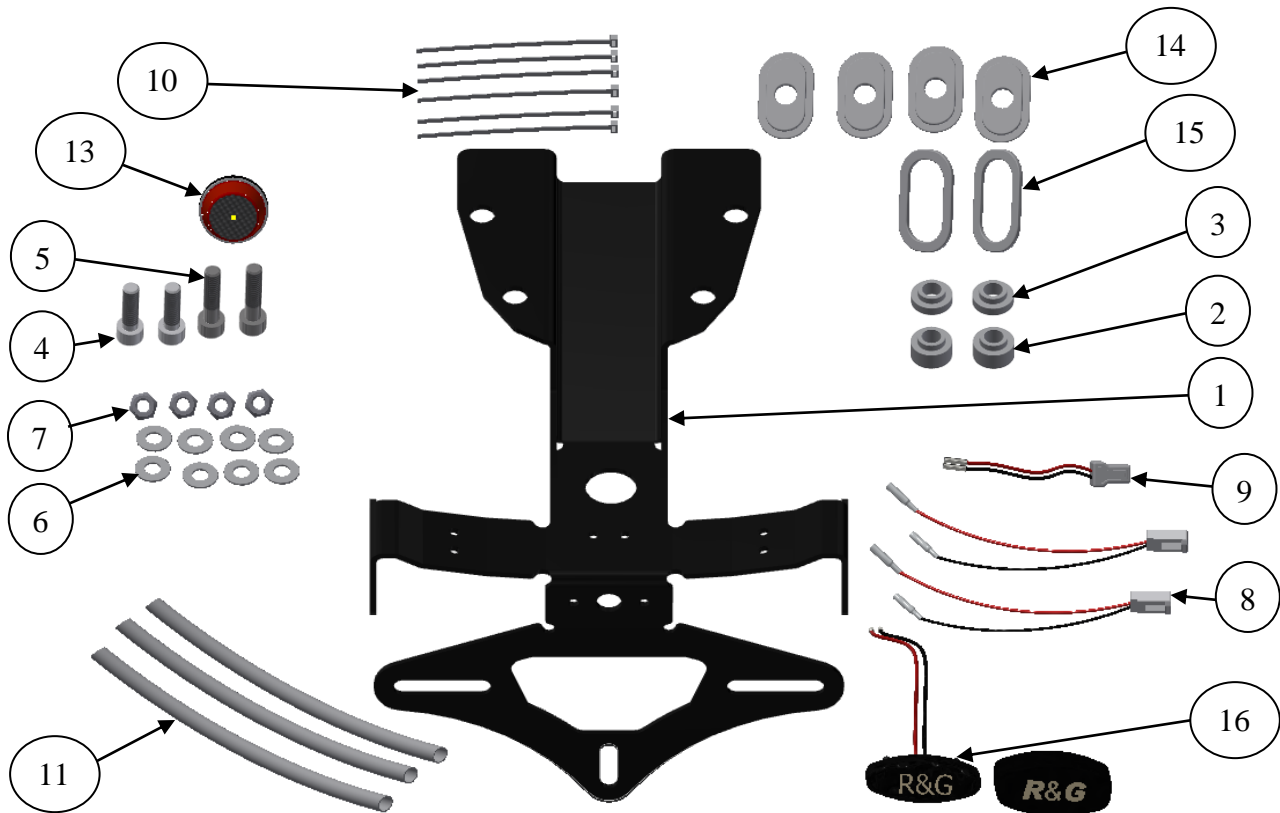

**MONTAGE ABBILDUNGEN**



Abbildung 1



Abbildung 2

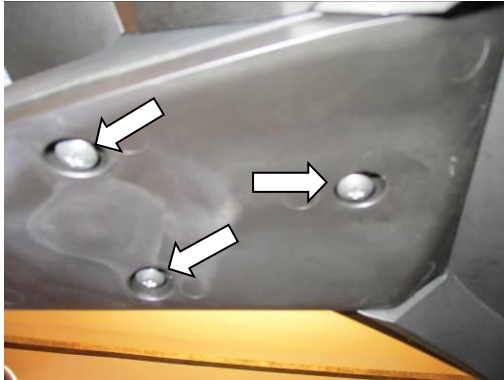

Abbildung 3



Abbildung 4



Abbildung 5

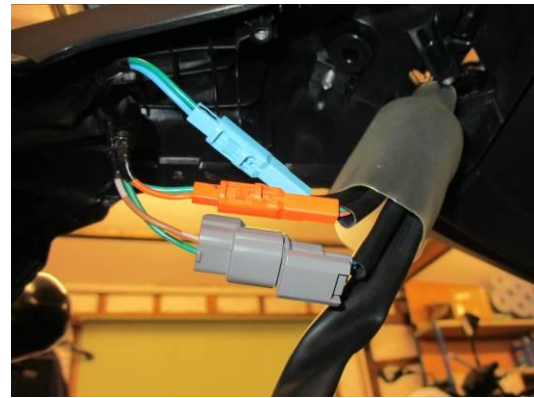

Abbildung 6



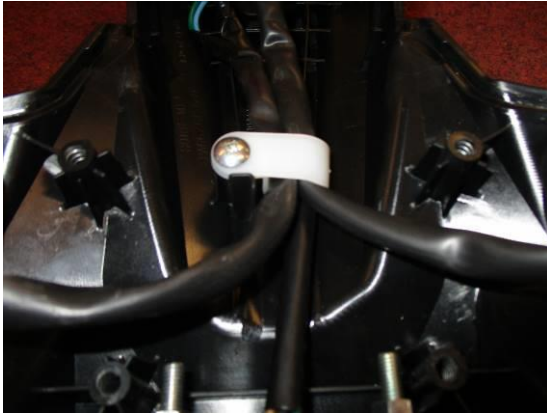

**Abbildung 7**



**Abbildung 8**



**Abbildung 9**



**Abbildung 10**



**Abbildung 11**



**Abbildung 12**



Abbildung 13



Abbildung 14



Abbildung 15



Abbildung 16

## **MONTAGEANLEITUNG**

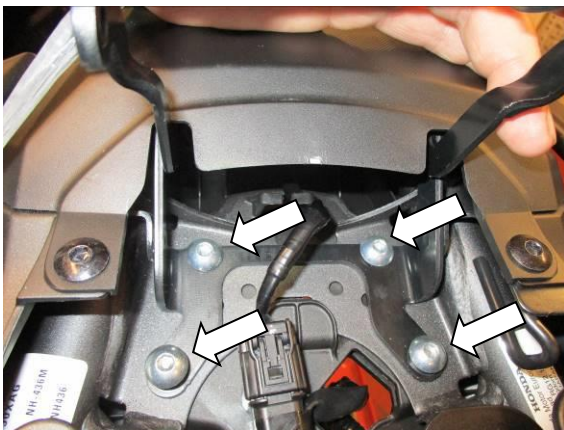
- Entfernen Sie den Sitz.
- Entfernen Sie die sieben Schrauben, die in den Abbildungen 1 und 2 gekennzeichnet sind.
- Lösen und entfernen Sie die Kabelabdeckung, um Zugang zu den Steckverbindungen zu ermöglichen.
- Lösen Sie den Kabelbinder, der in Abbildung 3 gekennzeichnet ist.
- Trennen Sie die Steckverbinder für die Blinker und die Kennzeichenbeleuchtung, die in Abbildung 4 mit Pfeilen gekennzeichnet sind (*Es empfiehlt sich, die zusammenpassenden Steckverbinder entsprechend zu markieren, um das Anschließen später zu erleichtern*).
- Entfernen Sie die vier Schrauben, die in Abbildung 5 gekennzeichnet sind.
- Den Kennzeichenhalter vorsichtig vom Motorrad entfernen und die Verkabelung gleichzeitig durch die Öffnung im original Kennzeichenhalter führen –siehe Abbildung 6.
- Führen Sie die Kabel durch die Öffnung an der unteren Abdeckung in das Fach unter dem Sitz.

### **Wenn Sie die Originalblinker wieder montieren:**

- Entfernen Sie die Kabelklemme, die in Abbildung 7 mit einem Pfeil gekennzeichnet ist.
- Entfernen Sie die Schraube, die in Abbildung 8 markiert ist, und entfernen Sie den Blinker wie in Abbildung 9 abgebildet.
- Entfernen Sie die Klemmhalterung für den Blinker wie in Abbildung 10 abgebildet.

R&G Racing

Unit 1, Shelley's Lane, East Worldham, Alton, Hampshire, GU34 3AQ

Tel: +44 (0)1420 89007 Fax: +44 (0)1420 87301 [www.rg-racing.com](http://www.rg-racing.com) Email: [info@rg-racing.com](mailto:info@rg-racing.com)





- Entfernen Sie den Blinker-Gummi wie in Abbildung 11 abgebildet.
- Wiederholen Sie diese Schritte für den übrigen Blinker.
- Die Distanzhalter (Artikel 3) am original Blinker-Gummi montieren wie unten abgebildet:



- Montieren Sie die Originalblinker am neuen Kennzeichenhalter (Artikel 1) wie in Abbildung 12 abgebildet und diese befestigen wie ursprünglich wieder.

### **Wenn Sie Miniblinker montieren:**

- Um die R&G Miniblinker montieren zu können, jeweils 1 x Schrumpfschlauch (Artikel 11) an den Kabeln der zwei Blinker anbringen.
- Positionieren Sie jeweils zwei Blinker-Adapter (Artikel 14) an den Kabeln der zwei Blinker – bitte darauf achten, dass die Seiten mit mittig-erhöhter Profil gegenüberliegend positioniert sind, bevor Sie die Flanschmutter montieren wie unten abgebildet:



- Montieren Sie die R&G Kennzeichenbeleuchtung (Artikel 16) wie in den Abbildungen 13 und 14 abgebildet.
- Benutzen Sie die mitgelieferten Kabelbinder und Kabelclips, um die Kabel ordentlich in Position zu halten.
- Legen Sie den Kennzeichenhalter auf das Hinterrad und führen Sie die Kabel durch die Öffnung an der Unterseite des hinteren Hilfsrahmens.
- Die Kennzeichenhalter-Einheit an der Unterseite des Hecks anbringen (wie in den oberen Abbildungen abgebildet). Eine der vier M6 x 25mm Inbusschrauben (Artikel 5) zusammen mit einer Unterlegscheibe (Artikel 6) von der Unterseite des Kennzeichenhalters beginnend durch den Kennzeichenhalter in den Aufnahmepunkt innerhalb des hinteren Hilfsrahmens einführen – siehe Abbildung 15. Das oben hervorstehende Gewinde mit einer M6 selbstsichernden Mutter (Artikel 7) versehen und lose befestigen.
- Die drei übrigen Schrauben und Unterlegscheiben auf der gleichen Weise wie im vorherigen Schritt montieren und die selbstsichernden Muttern lose befestigen.
- Wenn alle 4 Schrauben in Position sind, können diese gleichmäßig befestigt werden. *Bitte darauf achten, dass die Kabel nicht eingeklemmt sind.*

R&G Racing

Unit 1, Shelley's Lane, East Worldham, Alton, Hampshire, GU34 3AQ

Tel: +44 (0)1420 89007 Fax: +44 (0)1420 87301 [www.rg-racing.com](http://www.rg-racing.com) Email: [info@rg-racing.com](mailto:info@rg-racing.com)



- Verbinden Sie nun die Kennzeichenbeleuchtung mit dem mitgelieferten Steckverbinder (falls die Kennzeichenbeleuchtung nicht funktionieren sollte, einfach die Kabelverbindungen untereinander tauschen). Wenn Sie die Originalblinker montiert haben, verbinden Sie die Kabel am Kabelbaum wie ursprünglich wieder (diese sind farbcodiert) und überprüfen Sie die Funktion der Blinker und Beleuchtung. Wenn Sie R&G Miniblinker verwenden, bitte die zwei übrigen Verbindungen (Artikel 8) benutzen, um die Kabel am Kabelbaum anzuschließen. Wenn Sie R&G LED-Blinker montiert haben, benötigen Sie eventuell Widerstände (R&G Artikel-Nr. RGR0001), um die richtige Blitzgeschwindigkeit einzustellen (falls die Kennzeichenbeleuchtung nicht funktionieren sollte, einfach die Kabelverbindungen untereinander tauschen).
- Montieren Sie den Sitz und das amtliche Kennzeichen wieder.
- Entsprechend der gesetzlichen Vorschriften, den mitgelieferten Rückstrahler (Artikel 13) anbringen.
- **Überprüfen Sie die Funktion der Beleuchtung (Blinker und Kennzeichenhalter-Beleuchtung) vor Gebrauch des Fahrzeuges.**

#### **HINWEIS:**

WICHTIG: WENN EIN GROSSES KENNZEICHEN ZU WEIT NACH UNTEN MONTIERT WIRD, BESTEHT BEI SCHWERER LAST ODER DURCH GROSSE BODENWELLEN EIN GERINGES RISIKO, DASS DAS KENNZEICHEN AN DAS HINTERRAD STOSSEN KANN. ES LIEGT IN IHRER VERANTWORTUNG DIES ZU ÜBERPRÜFEN UND, WENN NOTWENDIG, VORBEUGENDE MASSNAHMEN VORZUNEHMEN! DIE NICHTBEACHTUNG DIESES SICHERHEITSHINWEISES KANN ZU SCHWEREN VERLETZUNGEN FÜHREN.

AUSGABE 1 – 13/09/2021 (WW)

#### **CONSUMER NOTICE**

The catalogue description and any exhibition of samples are only broad indications of the Products and R&G may make design changes which do not diminish their performance or visual appeal and supplying them in such state shall conform to the order. The Buyer acknowledges no representation or warranty (other than as to title) has been given or will apply to the Products other than those in R&G's order or confirmation and the Buyer confirms it has chosen the Products as being of merchantable quality and suitable for its particular purposes. Where R&G fits the Products or undertakes other services it shall exercise reasonable skill and care and rectify any fault free of charge unless the workmanship has been disturbed. The Buyer is responsible for ensuring that the warranty on the motorcycle is not affected by the fitting of the Products. On return of any defective Products R&G shall at its option either supply a replacement or refund the purchase money but shall not be liable if the Products have been modified or used or maintained otherwise than in accordance with R&G's or manufacturer's instructions and good engineering practice or if the defect arises from accident or neglect. Other than identified above and subject to R&G not limiting its liability for causing death and personal injury, it shall not be liable for indirect or consequential loss and otherwise its liability shall be limited to the amounts paid by the Buyer for the Products or the fitting or service concerned. These terms do not affect the Buyer's statutory rights.

#### **R&G RACING RETURNS POLICY (NON-FAULTY GOODS)**

Returns must be pre-authorized (if not pre-authorized the return will be rejected). Goods may only be returned direct to us if they were purchased direct from us (customer must prove if necessary). Otherwise to be returned to original vendor. Goods must be in re-sellable condition, in the opinion of R&G Racing. All returns are subject to a 25% restocking and handling fee (25% of the gross value exc. P&P – at the prevailing price at time of purchase). The customer must pay any and all carriage charges. No returns of discontinued products, unless within 14 days of purchase. This policy does not affect your statutory rights and does not refer to faulty goods.

R&G Racing

Unit 1, Shelley's Lane, East Worldham, Alton, Hampshire, GU34 3AQ

Tel: +44 (0)1420 89007 Fax: +44 (0)1420 87301 [www.rg-racing.com](http://www.rg-racing.com) Email: [info@rg-racing.com](mailto:info@rg-racing.com)