



FITTING INSTRUCTIONS FOR LP0385BK LICENCE PLATE BRACKET



**This kit contains the items pictured and labelled over page.
Some parts may be shown for clarity of instructions only.
Do not proceed until you are sure all parts are present.
Please read all instructions before proceeding.**

**IF IN ANY DOUBT WHEN FITTING OUR PRODUCTS, CONSULT ONE OF OUR DEALERS
OR HAVE FITTED BY A QUALIFIED TECHNICIAN.**

Please note that the way the kit is packed does not necessarily represent the way of mounting to the bike.

In the event of rubber washers being used to hold components onto bolts, these rubber washers can be thrown away.



<u>TOOLS REQUIRED</u>	<u>GENERAL TORQUE SETTINGS</u>
<ul style="list-style-type: none"> • Set of metric Hex keys to include 3mm, 4mm and 5mm. • Set of metric sockets and wrench. To include 6, 8 & 10mm. <ul style="list-style-type: none"> • 8mm & 10mm spanners. • Phillips screwdriver. 	M4 BOLT = 8Nm M5 BOLT = 12Nm M6 BOLT = 15Nm M8 BOLT = 20Nm M10 BOLT = 40Nm M12 BOLT = 40Nm

LEGEND

ITEM No.	DESCRIPTION	QTY
ITEM 1	MAIN MOUNTING BRACKET	1
ITEM 2	MIDDLE COVER PLATE	1
ITEM 3	LHS COVER PLATE	1
ITEM 4	RHS COVER PLATE	1
ITEM 5	12mm LONG SPACER	2
ITEM 6	RUBBER BUNG	1
ITEM 7	40mm BUTTON HEAD BOLT	2
ITEM 8	12mm BUTTON HEAD BOLT	2
ITEM 9	15mm BUTTON HEAD BOLT	2
ITEM 10	NYLOC NUT	2
ITEM 11	FLAT WASHER	8
ITEM 12	WIRING CONNECTOR	1
ITEM 13	75mm LONG CABLE TIE	4
ITEM 14	LICENCE PLATE LIGHT	1

R&G

Unit 1, Shelley's Lane, East Worldham, Alton, Hampshire, GU34 3AQ
 Tel: +44 (0)1420 89007 www.rg-racing.com Email: info@rg-racing.com



FITTING PICTURES

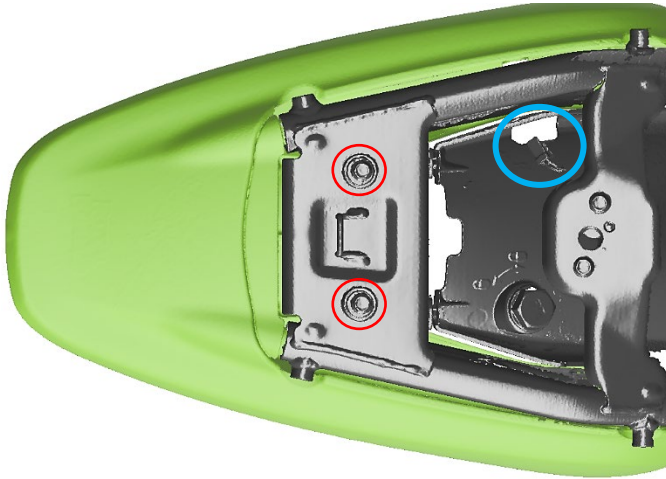

Picture 1

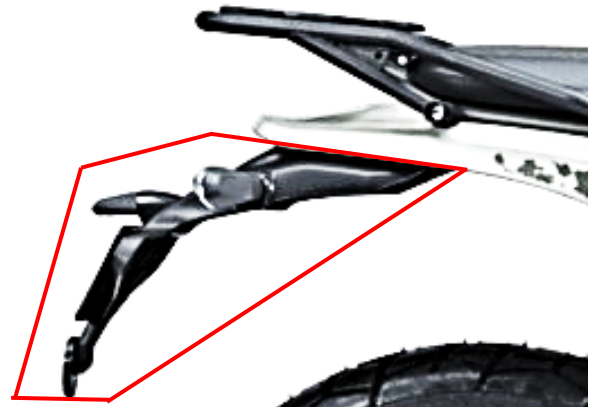

Picture 2

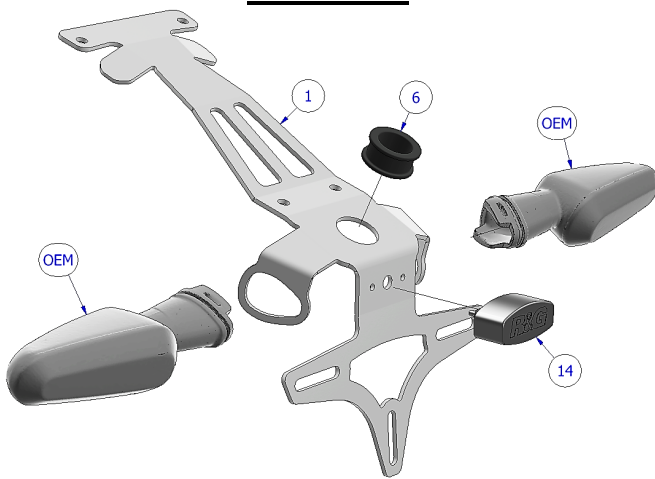

Picture 4

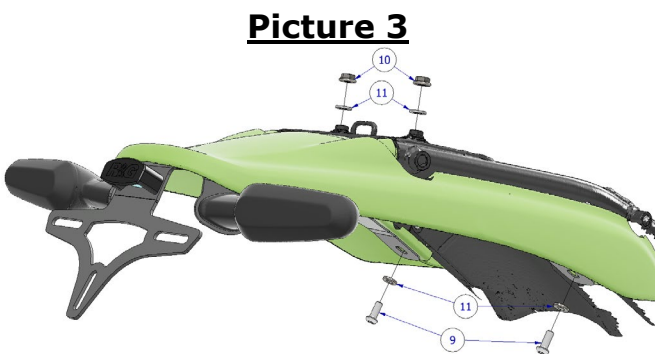

Picture 3

Picture 5

Picture 6



Before assembling this product, ensure all the components within the box are correct by comparing the legend and diagrams.

FITTING INSTRUCTIONS

Before fitting the R&G tail tidy you will need to remove some OEM parts. Below is a list of parts to be removed.

- Seat unit
- Rear fender (Shown in green in **Picture 1**)
Remove via the 2X bolts under the passenger seat (Circled in red in **Picture 1**) and all visible bolts in the undertray.
- Under tray/number plate panels (Marked in **Picture 2**)
Wiring will have to be disconnected to do so.
- Indicator/brake lights (to re-use with Tail Tidy)
- Sub-loom for rear light units

Tail Tidy Assembly

Due to the high level of vibration found in single cylinder motorcycles, it is recommended that a thread locking compound be used on all fasteners, with the exception of any nyloc/locking nuts.

- Once you have disassembled the original rear end, assemble the components as shown in **Picture 3** routing the indicator/brake light wiring up through the rubber bung/ **Item 6**.
- Connect the brake light/indicator wiring to the sub-loom you have removed previously.
- Using the supplied heat shrink, cable ties and self-adhesive cable clips, protect and tidy the wiring.
- The wiring should then be connected and routed up through the hole highlighted blue in **Picture 1**.

At this point the rear lights functionality should be tested before moving on (brake, tail and indicators)

- Making sure not to pinch the wiring, offer up the assembly to the rear fender (while off the bike) and fasten in place using the supplied M6x12mm button head bolts and washers (**Items 8 & 11**) in the rearward mounting points. (See **Picture 4**)
- Slip the 2x spacers (**Item 5**) underneath the main mounting plate (**Item 1**), they should be held in place between the fender and mounting plate while the fender assembly is mounted to the bike.
- With all cover plates and fasteners close to hand (**Items 2, 3, 4, 7 & 11**). Offer up the assembly to the bike then pass the 40mm bolts with washers through all cover plates, main bracket and lastly the subframe.

*Using **Picture 5** as a reference*

- On the top side of the subframe apply the nyloc nuts & washers loosely to the top of the 40mm bolts.
- Then fit the 2x15mm bolts (**Item 9**) with washers (**11**) to other end of both left- and right-hand side cover plates (**Items 3 & 4**)

Check the routing of the wiring before/as you are tightening down to ensure it is not pinched.

- Slowly tighten down each of the 4x mounting bolts to their required torque spec then finally the 2x cover plate bolts.

R&G

Unit 1, Shelley's Lane, East Worldham, Alton, Hampshire, GU34 3AQ
Tel: +44 (0)1420 89007 www.rg-racing.com Email: info@rg-racing.com



IMPORTANT: IF FITTING A FULL-SIZE LICENCE PLATE AND PLACING IT LOW DOWN ON THE LICENCE PLATE MOUNT, THERE IS A POTENTIAL CHANCE THE LICENCE PLATE COULD HIT THE BACK WHEEL UNDER HEAVY LOAD AND OVER LARGE BUMPS IN THE ROAD. IT IS YOUR RESPONSIBILITY TO CHECK FOR THIS POSSIBILITY AND TAKE AVOIDING ACTION. FAILURE TO CHECK THIS COULD RESULT IN SERIOUS INJURY.

ISS 1 31/10/2024 (TB)

CONSUMER NOTICE

The catalogue description and any exhibition of samples are only broad indications of the Products and R&G may make design changes which do not diminish their performance or visual appeal and supplying them in such state shall conform to the order. The Buyer acknowledges no representation or warranty (other than as to title) has been given or will apply to the Products other than those in R&G's order or confirmation and the Buyer confirms it has chosen the Products as being of merchantable quality and suitable for its particular purposes. Where R&G fits the Products or undertakes other services it shall exercise reasonable skill and care and rectify any fault free of charge unless the workmanship has been disturbed. The Buyer is responsible for ensuring that the warranty on the motorcycle is not affected by the fitting of the Products. On return of any defective Products R&G shall at its option either supply a replacement or refund the purchase money but shall not be liable if the Products have been modified or used or maintained otherwise than in accordance with R&G's or manufacturer's instructions and good engineering practice or if the defect arises from accident or neglect. Other than identified above and subject to R&G not limiting its liability for causing death and personal injury, it shall not be liable for indirect or consequential loss and otherwise its liability shall be limited to the amounts paid by the Buyer for the Products or the fitting or service concerned. These terms do not affect the Buyer's statutory rights.

R&G RACING RETURNS POLICY (NON-FAULTY GOODS)

Returns must be pre-authorized (if not pre-authorized the return will be rejected). Goods may only be returned direct to us if they were purchased direct from us (customer must prove if necessary). Otherwise to be returned to original vendor. Goods must be in re-sellable condition, in the opinion of R&G Racing. All returns are subject to a 25% restocking and handling fee (25% of the gross value exc. P&P – at the prevailing price at time of purchase). The customer must pay any and all carriage charges. No returns of discontinued products, unless within 14 days of purchase. This policy does not affect your statutory rights and does not refer to faulty goods.

R&G

Unit 1, Shelley's Lane, East Worldham, Alton, Hampshire, GU34 3AQ
Tel: +44 (0)1420 89007 www.rg-racing.com Email: info@rg-racing.com



NOTICE DE MONTAGE LP0385BK SUPPORT DE PLAQUE



CE KIT CONTIENT LES ARTICLES ILLUSTRÉS ET ÉTIQUETES SUR LA PAGE.

CERTAINES PARTIES PEUVENT ÊTRE PRÉSENTES UNIQUEMENT POUR LA CLARTÉ DES INSTRUCTIONS.

NE PAS PROCÉDER AU MONTAGE TANT QUE VOUS N'ÊTES PAS SÛR QUE TOUTES LES PIÈCES SOIENT PRÉSENTES.

VEUILLEZ LIRE TOUTES LES INSTRUCTIONS AVANT DE CONTINUER.

EN CAS DE DOUTE LORS DU MONTAGE DE NOS PRODUITS, CONSULTEZ UN DE NOS REVENDEURS OU FAITES APPEL À UN TECHNICIEN QUALIFIÉ.

VEUILLEZ NOTER QUE LA FAÇON DONT LE KIT EST EMBALLÉ NE REPRÉSENTE PAS NECESSAIREMENT LA MANIÈRE DE LE MONTER SUR LA MOTO.

SI DES RONDELLES EN CAOUTCHOUC SONT UTILISÉES POUR MAINTENIR LES COMPOSANTS SUR LES BOULONS, ELLES PEUVENT ÊTRE JETÉES.

NOTICE DISPONIBLE AU TÉLÉCHARGEMENT SUR :



WWW.RG-RACING.COM

<u>TOOLS REQUIRED</u>	<u>VALEURS DE SERRAGE</u>
<u>OUTILS REQUIS</u> <ul style="list-style-type: none"> • Ensemble de clés hexagonales métriques de 3mm, 4mm et 5mm. <ul style="list-style-type: none"> • Jeu de douilles et de clés métriques 6, 8 & 10mm. • Clé à molette 8mm & 10mm <ul style="list-style-type: none"> • Tournevis cruciforme. 	M4 BOULON = 8Nm M5 BOULON = 12Nm M6 BOULON = 15Nm M8 BOULON = 20Nm M10 BOULON = 40Nm M12 BOULON = 40Nm

LÉGENDE

ARTICLE No.	DESCRIPTION	QTÉ
ARTICLE 1	SUPPORT PRINCIPAL	1
ARTICLE 2	MIDDLE COVER PLATE	1
ARTICLE 3	PLAQUE DE COUVERTURE GAUCHE	1
ARTICLE 4	PLAQUE DE COUVERTURE DROITE	1
ARTICLE 5	12mm ENTRETOISE	2
ARTICLE 6	RUBBER BUNG	1
ARTICLE 7	40mm BOULON	2
ARTICLE 8	12mm BOULON	2
ARTICLE 9	15mm BOULON	2
ARTICLE 10	ÉCROU	2
ARTICLE 11	RONDELLE PLATE	8
ARTICLE 12	CONNECTEUR DE FIL	1
ARTICLE 13	75mm COLLIER DE SERRAGE	4
ARTICLE 14	FEU DE PLAQUE	1

R&G

Unit 1, Shelley's Lane, East Worldham, Alton, Hampshire, GU34 3AQ
 Tel: +44 (0)1420 89007 www.rg-racing.com Email: info@rg-racing.com



PHOTOS DE MONTAGE

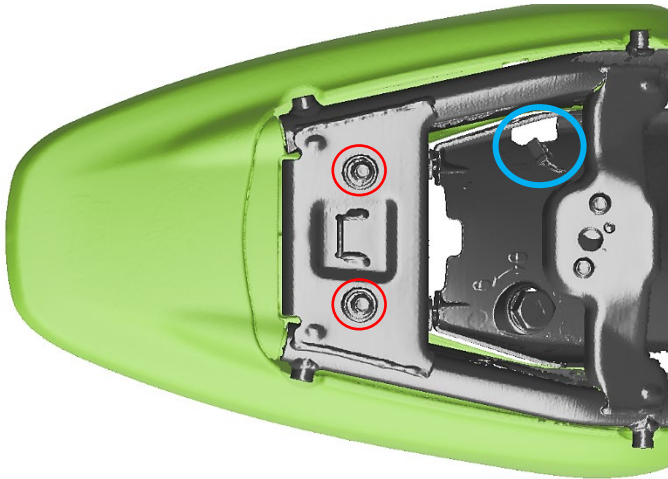

Photo 1

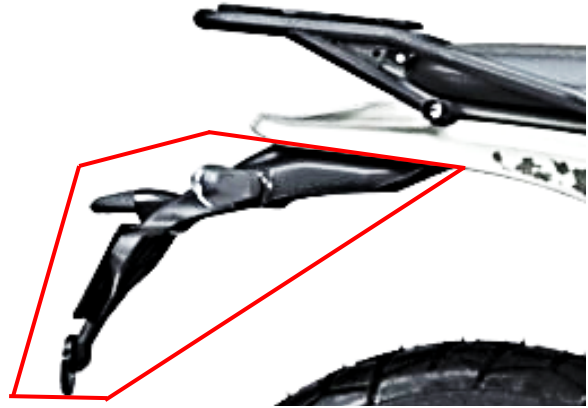

Photo 2

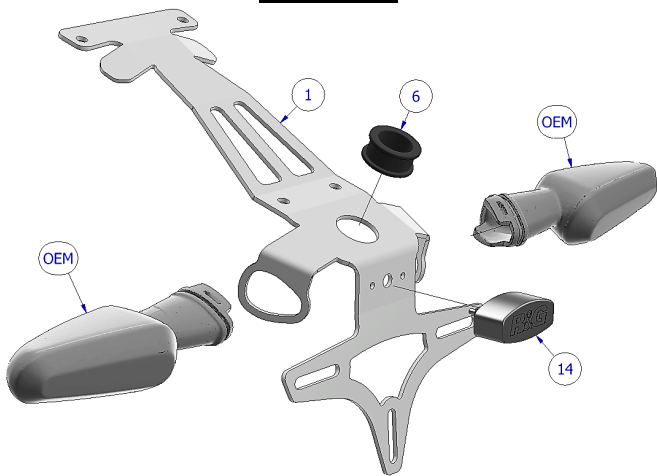
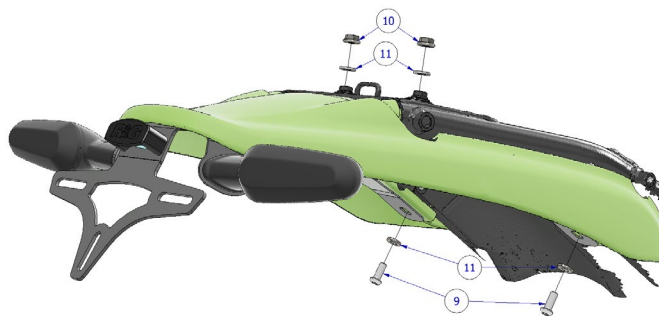

Photo 3



Photo 4

**Photo 5****Photo 6**

Avant d'assembler ce produit, assurez-vous que tous les composants de la boîte soient corrects en comparant la légende et les schémas

NOTICE DE MONTAGE

Avant d'installer le support R&G, vous devrez retirer certaines pièces d'origine. Vous trouverez ci-dessous une liste des pièces à retirer.

- Siège
- Garde-boue arrière (montré en vert sur la photo 1)
- Retirez-le via les 2 boulons sous le siège passager (entourés en rouge sur la photo 1) et tous les boulons visibles dans le dessous de caisse.
- Panneaux de dessous de caisse/plaque d'immatriculation (marqués sur la photo 2)
- Le câblage devra être débranché pour ce faire.
- Clignotants/feux stop (à réutiliser avec le support)
- Sous-faisceau pour feux arrière

Assemblage du support de queue

En raison du niveau élevé de vibrations rencontré avec les motos monocylindres, il est recommandé d'utiliser un composé de blocage de filetage sur toutes les fixations, à l'exception des écrous Nyloc/de blocage.

- Une fois que vous avez démonté l'arrière d'origine, assemblez les composants comme indiqué sur la photo 3 en faisant passer le câblage du clignotant/feu stop à travers le bouchon en caoutchouc/article 6.
- Connectez le câblage du feu stop/clignotant au sous-faisceau que vous avez retiré précédemment.
- À l'aide du manchon thermorétractable, des colliers de serrage et des clips de câble auto-adhésifs fournis, protégez et rangez le câblage.
- Le câblage doit ensuite être connecté et acheminé à travers le trou surligné en bleu sur la photo 1.

À ce stade, la fonctionnalité des feux arrière doit être testée avant de continuer (frein, feu arrière et clignotants))

- En veillant à ne pas pincer le câblage, présentez l'ensemble sur le garde-boue arrière (en étant hors de la moto) et fixez-le en place à l'aide des boulons à tête bombée M6x12 mm et des rondelles fournis (articles 8 et 11) dans les points de montage arrière (Voir photo 4).
- Glissez les 2x entretoises (article 5) sous la plaque de montage principale (article 1), elles doivent être maintenues en place entre le garde-boue et la plaque de montage pendant que l'ensemble du garde-boue est monté sur la moto.

R&G

Unit 1, Shelley's Lane, East Worldham, Alton, Hampshire, GU34 3AQ

Tel: +44 (0)1420 89007 Fax: +44 (0)1420 87301 www.rg-racing.com Email: info@rg-racing.com



- Avec toutes les plaques de recouvrement et les fixations à portée de main (articles 2, 3, 4, 7 et 11). Présentez l'ensemble sur la moto, puis passez les boulons de 40 mm avec les rondelles à travers toutes les plaques de recouvrement, le support principal et enfin le sous-châssis.
- En utilisant la photo 5 comme référence.
- Du côté supérieur du sous-châssis, appliquez les écrous et les rondelles nyloc sans serrer sur le dessus des boulons de 40 mm.
- Ensuite, installez les 2 boulons de 15 mm (article 9) avec les rondelles (11) à l'autre extrémité des plaques de recouvrement latérales gauche et droite (articles 3 et 4)
- Vérifiez l'acheminement du câblage avant/pendant le serrage pour vous assurer qu'il n'est pas pincé.
- Serrez lentement chacun des 4 boulons de montage au couple requis, puis enfin les 2 boulons de la plaque de recouvrement.

IMPORTANT : SI VOUS MONTEZ UNE PLAQUE D'IMMATRICULATION DE GRANDE TAILLE ET LA PLACEZ BIEN EN BAS SUR LE SUPPORT DE PLAQUE D'IMMATRICULATION, IL Y A UN RISQUE QUE LA PLAQUE D'IMMATRICULATION FRAPPE LA ROUE ARRIÈRE SOUS UNE CHARGE LOURDE ET SUR DE GROSSES BOSSES SUR LA ROUTE. IL EST DE VOTRE RESPONSABILITÉ DE VÉRIFIER CETTE POSSIBILITÉ ET DE PRENDRE DES MESURES POUR ÉVITER. NE PAS VÉRIFIER CELA POURRAIT ENTRAÎNER DES BLESSURES GRAVES.

ISS 1 31/10/2024 (TB)

CONSUMER NOTICE

The catalogue description and any exhibition of samples are only broad indications of the Products and R&G may make design changes which do not diminish their performance or visual appeal and supplying them in such state shall conform to the order. The Buyer acknowledges no representation or warranty (other than as to title) has been given or will apply to the Products other than those in R&G's order or confirmation and the Buyer confirms it has chosen the Products as being of merchantable quality and suitable for its particular purposes. Where R&G fits the Products or undertakes other services it shall exercise reasonable skill and care and rectify any fault free of charge unless the workmanship has been disturbed. The Buyer is responsible for ensuring that the warranty on the motorcycle is not affected by the fitting of the Products. On return of any defective Products R&G shall at its option either supply a replacement or refund the purchase money but shall not be liable if the Products have been modified or used or maintained otherwise than in accordance with R&G's or manufacturer's instructions and good engineering practice or if the defect arises from accident or neglect. Other than identified above and subject to R&G not limiting its liability for causing death and personal injury, it shall not be liable for indirect or consequential loss and otherwise its liability shall be limited to the amounts paid by the Buyer for the Products or the fitting or service concerned. These terms do not affect the Buyer's statutory rights.

R&G RACING RETURNS POLICY (NON-FAULTY GOODS)

Returns must be pre-authorized (if not pre-authorized the return will be rejected). Goods may only be returned direct to us if they were purchased direct from us (customer must prove if necessary). Otherwise to be returned to original vendor. Goods must be in re-sellable condition, in the opinion of R&G Racing. All returns are subject to a 25% restocking and handling fee (25% of the gross value exc. P&P – at the prevailing price at time of purchase). The customer must pay any and all carriage charges. No returns of discontinued products, unless within 14 days of purchase. This policy does not affect your statutory rights and does not refer to faulty goods.

R&G

Unit 1, Shelley's Lane, East Worldham, Alton, Hampshire, GU34 3AQ

Tel: +44 (0)1420 89007 Fax: +44 (0)1420 87301 www.rg-racing.com Email: info@rg-racing.com