



## **FITTING INSTRUCTIONS FOR RAD0286**



**THIS KIT CONTAINS THE ITEMS PICTURED AND LABELLED OVER PAGE.**

SOME PARTS MAY BE SHOWN FOR CLARITY OF INSTRUCTIONS ONLY.

DO NOT PROCEED UNTIL YOU ARE SURE ALL PARTS ARE PRESENT.

**PLEASE READ ALL INSTRUCTIONS BEFORE PROCEEDING.**

**IF IN ANY DOUBT WHEN FITTING OUR PRODUCTS, CONSULT ONE OF OUR DEALERS  
OR HAVE FITTED BY A QUALIFIED TECHNICIAN.**

PLEASE NOTE THAT THE WAY THE KIT IS PACKED DOES NOT NECESSARILY REPRESENT THE WAY OF  
MOUNTING TO THE BIKE.

IN THE EVENT OF RUBBER WASHERS BEING USED TO HOLD COMPONENTS ONTO BOLTS,  
THESE RUBBER WASHERS CAN BE THROWN AWAY.

**DIGITAL COPIES OF THESE INSTRUCTIONS ARE AVAILABLE FROM:**

[WWW.RG-RACING.COM](http://WWW.RG-RACING.COM)



<u>TOOLS REQUIRED</u>	<u>GENERAL TORQUE SETTINGS</u>
<ul style="list-style-type: none"> <li>• SET OF ALLEN KEYS                             <ul style="list-style-type: none"> <li>• SOCKET SET</li> </ul> </li> <li>• TORX SOCKET SET</li> </ul>	<p>M4 BOLT = 8Nm                      M5 BOLT = 12Nm                      M6 BOLT = 15Nm                      M8 BOLT = 20Nm                      M10 BOLT = 40Nm                      M12 BOLT = 40Nm</p>

**LEGEND**

ITEM NO.	DESCRIPTION	QTY
ITEM 1	RADIATOR GUARD (RAD0286)	1
ITEM 2	RUBBER GROMMETS	4
ITEM 3	CABLE TIE	4

**ASSEMBLY DIAGRAM**

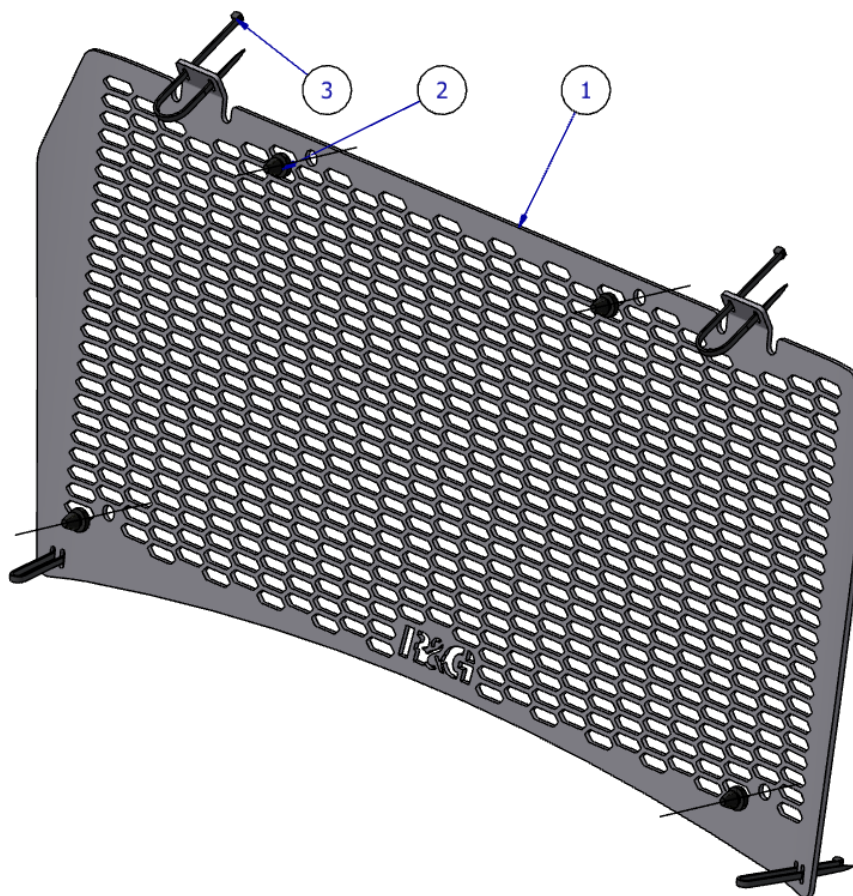



## **FITTING PICTURES**

Picture 1



Picture 2



Picture 3



Picture 4

## **FITTING INSTRUCTIONS**

1. To start this installation, you'll need to place the rubber grommets (**ITEM 2**) through the holes in the Radiator guard (**ITEM 1**) as shown in the **ASSEMBLY DIAGRAM**.
2. Then remove the two top bolts as located in **Picture 1**.
3. Remove the two lower bolts on the underside plastic as located in **Picture 2**.
4. Remove the two lower side panel bolts as located in **Picture 3**.
5. Removing these bolts will allow you to be able to move the fairings out of the way enough to get the OEM rad guard off. To do so you'll need to pry the OEM rad guard off as there is small little clips at the top and bottom.

R&G Racing

Unit 1, Shelley's Lane, East Worldham, Alton, Hampshire, GU34 3AQ

Tel: +44 (0)1420 89007 Fax: +44 (0)1420 87301 [www.rg-racing.com](http://www.rg-racing.com) Email: [info@rg-racing.com](mailto:info@rg-racing.com)



6. Once the OEM rad guard is removed, place the cable ties (**ITEM 3**) through the Radiator guard (**ITEM 1**) as shown in the assembly diagram.
7. Place the now assembled radiator guard up against the radiator and loop the cable ties around the top brackets and tighten.
8. To connect the lower cable ties there should be plastic tabs on the inner side of the fairings to loops them and tighten.
9. Once secure, you can place all the bolts back into the covers and fairings. **NOTE the OEM rad guard doesn't go back on, this kit is a replacement.**
10. Ensure all bolts are tightened correctly.

**See more R&G products for your Motorcycle in the link below:**

[R&G Racing | All Products for Aprilia - Tuareg 660 \(2023\) \(rg-racing.com\)](https://www.rg-racing.com)

ISSUE 1 06/01/2023 – (JH)

#### **CONSUMER NOTICE**

The catalogue description and any exhibition of samples are only broad indications of the Products and R&G may make design changes which do not diminish their performance or visual appeal and supplying them in such state shall conform to the order. The Buyer acknowledges no representation or warranty (other than as to title) has been given or will apply to the Products other than those in R&G's order or confirmation and the Buyer confirms it has chosen the Products as being of merchantable quality and suitable for its particular purposes. Where R&G fits the Products or undertakes other services it shall exercise reasonable skill and care and rectify any fault free of charge unless the workmanship has been disturbed. The Buyer is responsible for ensuring that the warranty on the motorcycle is not affected by the fitting of the Products. On return of any defective Products R&G shall at its option either supply a replacement or refund the purchase money but shall not be liable if the Products have been modified or used or maintained otherwise than in accordance with R&G's or manufacturer's instructions and good engineering practice or if the defect arises from accident or neglect. Other than identified above and subject to R&G not limiting its liability for causing death and personal injury, it shall not be liable for indirect or consequential loss and otherwise its liability shall be limited to the amounts paid by the Buyer for the Products or the fitting or service concerned. These terms do not affect the Buyer's statutory rights.

#### **R&G RACING RETURNS POLICY (NON-FAULTY GOODS)**

Returns must be pre-authorized (if not pre-authorized the return will be rejected). Goods may only be returned direct to us if they were purchased direct from us (customer must prove if necessary). Otherwise to be returned to original vendor. Goods must be in re-sellable condition, in the opinion of R&G Racing. All returns are subject to a 25% restocking and handling fee (25% of the gross value exc. P&P – at the prevailing price at time of purchase). The customer must pay any and all carriage charges. No returns of discontinued products, unless within 14 days of purchase. This policy does not affect your statutory rights and does not refer to faulty goods.

R&G Racing

Unit 1, Shelley's Lane, East Worldham, Alton, Hampshire, GU34 3AQ

Tel: +44 (0)1420 89007 Fax: +44 (0)1420 87301 [www.rg-racing.com](http://www.rg-racing.com) Email: [info@rg-racing.com](mailto:info@rg-racing.com)





## **NOTICE DE MONTAGE POUR RAD0286**



**CE KIT CONTIENT LES ARTICLES ILLUSTRÉS ET ÉTIQUETES SUR LA PAGE.**

CERTAINES PARTIES PEUVENT ÊTRE PRÉSENTES UNIQUEMENT POUR LA CLARTE DES INSTRUCTIONS.

NE PAS PROCÉDER AU MONTAGE TANT QUE VOUS N'ÊTES PAS SÛR QUE TOUTES LES PIÈCES SOIENT PRÉSENTES.

**VEUILLEZ LIRE TOUTES LES INSTRUCTIONS AVANT DE CONTINUER.**

**EN CAS DE DOUTE LORS DU MONTAGE DE NOS PRODUITS, CONSULTEZ UN DE NOS REVENDEURS OU FAITES APPEL A UN TECHNICIEN QUALIFIÉ.**

VEUILLEZ NOTER QUE LA FAÇON DONT LE KIT EST EMBALLÉ NE REPRÉSENTE PAS NECESSAIREMENT LA MANIÈRE DE LE MONTER SUR LA MOTO.

SI DES RONDELLES EN CAOUTCHOUC SONT UTILISÉES POUR MAINTENIR LES COMPOSANTS SUR LES BOULONS, ELLES PEUVENT ÊTRE JETÉES.

**NOTICE DISPONIBLE AU TÉLÉCHARGEMENT SUR :**

[WWW.RG-RACING.COM](http://WWW.RG-RACING.COM)

R&G Racing

Unit 1, Shelley's Lane, East Worldham, Alton, Hampshire, GU34 3AQ

Tel: +44 (0)1420 89007 Fax: +44 (0)1420 87301 [www.rg-racing.com](http://www.rg-racing.com) Email: [info@rg-racing.com](mailto:info@rg-racing.com)



<b><u>OUTILS REQUIS</u></b>	<b><u>VALEURS DE SERRAGE</u></b>
<ul style="list-style-type: none"> <li>• CLÉS ALLEN</li> <li>• CLÉ À CLIQUET</li> <li>• CLÉ TORX</li> </ul>	<p>M4 BOULON = 8Nm</p> <p>M5 BOULON = 12Nm</p> <p>M6 BOULON = 15Nm</p> <p>M8 BOULON = 20Nm</p> <p>M10 BOULON = 40Nm</p> <p>M12 BOULON = 40Nm</p>

### **LÉGENDE**

<b>ARTICLE NO.</b>	<b>DESCRIPTION</b>	<b>QTÉ</b>
ARTICLE 1	PROTECTION RADIATEUR (RAD0286)	1
ARTICLE 2	ŒILLETS EN CAOUTCHOUC	4
ARTICLE 3	COLLIER DE SERRAGE	4

### **SCHÉMA D'ENSEMBLE**

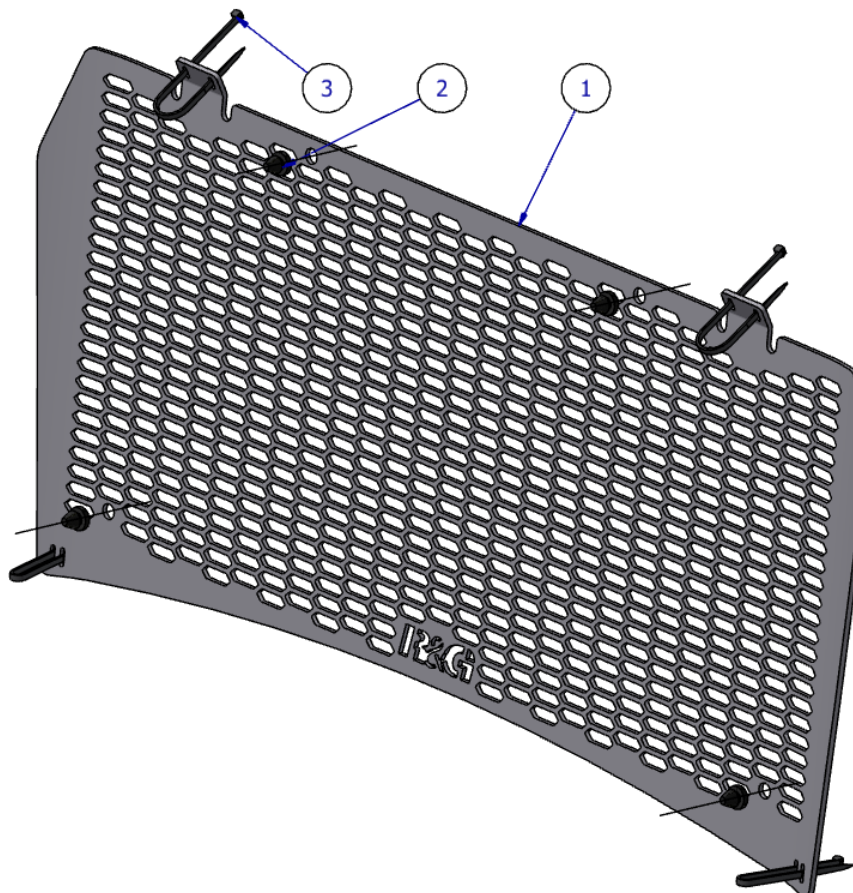



## PHOTOS DE MONTAGE

Photo 1



Photo 2



Photo 3



Photo 4

## NOTICE DE MONTAGE

11. Pour commencer cette installation, vous devrez placer les œillets en caoutchouc (ARTICLE 2) à travers les trous de la protection du radiateur (ARTICLE 1) comme indiqué sur le SCHÉMA D'ASSEMBLAGE.
12. Retirez ensuite les deux boulons supérieurs comme indiqué sur la photo 1.
13. Retirez les deux boulons inférieurs sur le plastique inférieur comme indiqué sur la photo 2.
14. Retirez les deux boulons du panneau latéral inférieur comme indiqué sur la photo 3.

R&G Racing

Unit 1, Shelley's Lane, East Worldham, Alton, Hampshire, GU34 3AQ

Tel: +44 (0)1420 89007 Fax: +44 (0)1420 87301 [www.rg-racing.com](http://www.rg-racing.com) Email: [info@rg-racing.com](mailto:info@rg-racing.com)



15. Le retrait de ces boulons vous permettra de pouvoir écarter suffisamment les carénages pour retirer la protection d'origine. Pour ce faire, vous devrez soulever la protection d'origine car il y a des petits clips en haut et en bas.
  16. Une fois la protection d'origine retirée, placez les colliers de serrage (ARTICLE 3) à travers la protection (ARTICLE 1) comme indiqué sur le schéma de montage.
  17. Placez la protection radiateur assemblée contre le radiateur et enroulez les colliers de serrage autour des supports supérieurs et serrez.
  18. 8Pour connecter les colliers de serrage inférieurs, il doit y avoir des languettes en plastique sur le côté intérieur des carénages pour les boucler et les serrer.
  19. 9Une fois sécurisé, vous pouvez replacer tous les boulons dans les couvercles et les carénages.
- NOTE : Le garde-boue d'origine ne se remet pas en place, ce kit est un remplacement.
20. 10. Assurez-vous que tous les boulons soient correctement serrés.

**Voir plus de produits R&G pour votre moto via ce lien :**

[R&G Racing | All Products for Aprilia - Tuareg 660 \(2023\) \(rg-racing.com\)](http://rg-racing.com)

ISSUE 1 06/01/2023 - (JH)

#### **CONSUMER NOTICE**

The catalogue description and any exhibition of samples are only broad indications of the Products and R&G may make design changes which do not diminish their performance or visual appeal and supplying them in such state shall conform to the order. The Buyer acknowledges no representation or warranty (other than as to title) has been given or will apply to the Products other than those in R&G's order or confirmation and the Buyer confirms it has chosen the Products as being of merchantable quality and suitable for its particular purposes. Where R&G fits the Products or undertakes other services it shall exercise reasonable skill and care and rectify any fault free of charge unless the workmanship has been disturbed. The Buyer is responsible for ensuring that the warranty on the motorcycle is not affected by the fitting of the Products. On return of any defective Products R&G shall at its option either supply a replacement or refund the purchase money but shall not be liable if the Products have been modified or used or maintained otherwise than in accordance with R&G's or manufacturer's instructions and good engineering practice or if the defect arises from accident or neglect. Other than identified above and subject to R&G not limiting its liability for causing death and personal injury, it shall not be liable for indirect or consequential loss and otherwise its liability shall be limited to the amounts paid by the Buyer for the Products or the fitting or service concerned. These terms do not affect the Buyer's statutory rights.

#### **R&G RACING RETURNS POLICY (NON-FAULTY GOODS)**

Returns must be pre-authorized (if not pre-authorized the return will be rejected). Goods may only be returned direct to us if they were purchased direct from us (customer must prove if necessary). Otherwise to be returned to original vendor. Goods must be in re-sellable condition, in the opinion of R&G Racing. All returns are subject to a 25% restocking and handling fee (25% of the gross value exc. P&P - at the prevailing price at time of purchase). The customer must pay any and all carriage charges. No returns of discontinued products, unless within 14 days of purchase. This policy does not affect your statutory rights and does not refer to faulty goods.

R&G Racing

Unit 1, Shelley's Lane, East Worldham, Alton, Hampshire, GU34 3AQ

Tel: +44 (0)1420 89007 Fax: +44 (0)1420 87301 [www.rg-racing.com](http://www.rg-racing.com) Email: [info@rg-racing.com](mailto:info@rg-racing.com)





## **MONTAGEANLEITUNG FÜR RAD0286**



**ALLE KIT-TEILE SIND AUF DEN NACHFOLGENDEN SEITEN ABGEBILDET UND GEKENNZEICHNET.**

DIE ABGEBILDETEN TEILE DIENEN LEDIGLICH ZUR ERKLÄRUNG.

ÜBERPRÜFEN SIE ZUERST, DASS ALLE TEILE VORHANDEN SIND.

**LESEN SIE DIE MONTAGEANLEITUNG KOMPLETT DURCH, BEVOR SIE ANFANGEN.**

**WENN SIE BEI DER MONTAGE DIESES PRODUKTES UNSICHER SIND, BITTE EINEN UNSERER HÄNDLER KONTAKTIEREN ODER DAS KIT VON EINEM QUALIFIZIERTEN ZWEIRAD-MECHANIKER MONTIEREN LASSEN.**

DIE VERPACKUNG DER TEILE STELLT NICHT DIE REIHENFOLGE DER MONTAGE DAR.

HINWEIS FÜR KITS MIT PLASTIKUNTERLEGSCHIEBEN AN DEN SCHRAUBEN –  
DIESE PLASTIK-UNTERLEGSCHIEBEN WERDEN NICHT FÜR DEN EINBAU BENÖTIGT.

**EINE DIGITALE VERSION DIESER MONTAGEANLEITUNG KANN AUF FOLGENDER SEITE HERUNTERGELADEN WERDEN:**

[WWW.RG-RACING.COM](http://WWW.RG-RACING.COM)

R&G Racing

Unit 1, Shelley's Lane, East Worldham, Alton, Hampshire, GU34 3AQ

Tel: +44 (0)1420 89007 Fax: +44 (0)1420 87301 [www.rg-racing.com](http://www.rg-racing.com) Email: [info@rg-racing.com](mailto:info@rg-racing.com)



<b>SIE BENÖTIGEN FOLGENDE WERKZEUGE:</b>	<b>ALLGEM. ANZUGSDREHMOMENT</b>
<ul style="list-style-type: none"> <li>• SATZ INBUSSCHLÜSSEL</li> <li>• STECKSCHLÜSSEL</li> <li>• SATZ TORX-SCHLÜSSEL</li> </ul>	M4 SCHRAUBE = 8Nm M5 SCHRAUBE = 12Nm M6 SCHRAUBE = 15Nm M8 SCHRAUBE = 20Nm M10 SCHRAUBE = 40Nm M12 SCHRAUBE = 40Nm

### **LIEFERUMFANG**

<b>ARTIKEL NR.</b>	<b>BESCHREIBUNG</b>	<b>MENGE</b>
ARTIKEL 1	KÜHLERSCHUTZ (RAD0286)	1
ARTIKEL 2	GUMMITÜLLE	4
ARTIKEL 3	KABELBINDER	4

### **ZUSAMMENBAU ZEICHNUNG**

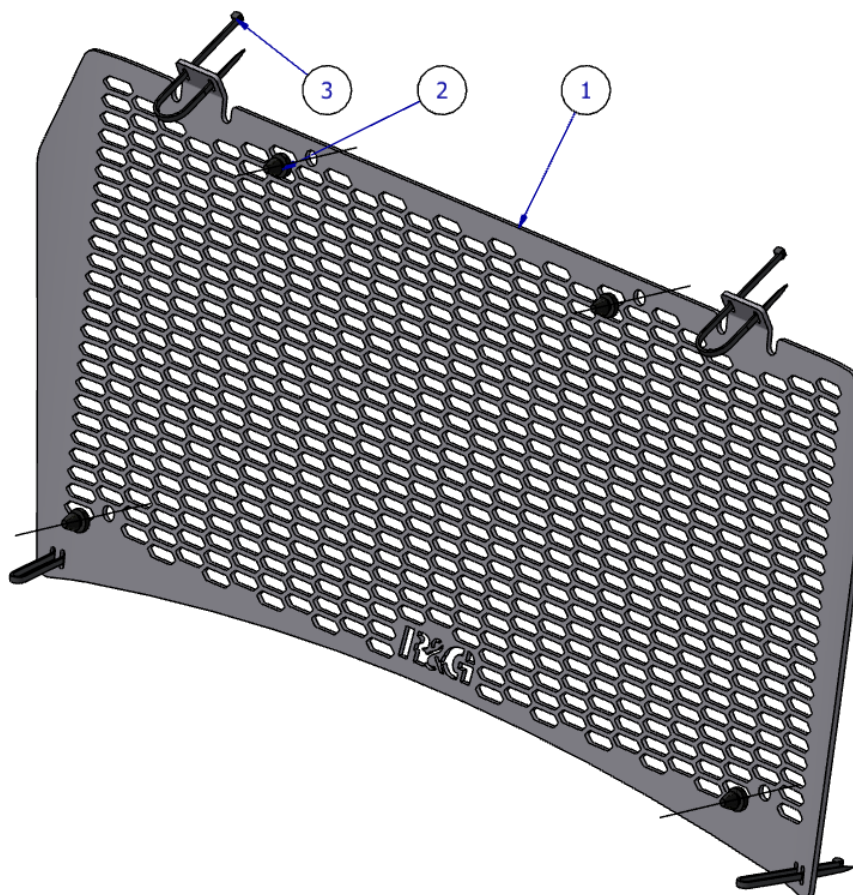

### **MONTAGE -**



## ABBILDUNGEN

Abbildung 1



Abbildung 2



Abbildung 3



Abbildung 4

## MONTAGEANLEITUNG

21. Um mit der Montage beginnen zu können, zuerst die Gummitüllen (**ARTIKEL 2**) durch die Öffnungen im Kühlerschutz (**ARTIKEL 1**) einsetzen wie in der **ZEICHNUNG ZUSAMMENBAU** abgebildet.
22. Danach entfernen Sie die zwei oberen Schrauben, die in **Abbildung 1** abgebildet sind.
23. Entfernen Sie die 2 unteren Schrauben an der Unterseite der Verkleidung – siehe **Abbildung 2**.
24. Entfernen Sie die 2 Schrauben für die untere Seitenverkleidungsteile – siehe **Abbildung 3**.
25. Nachdem diese Schrauben entfernt sind, können Sie die Verkleidungen soweit entfernen, dass Sie den original Kühlerschutz abbauen können. Sie müssen den original Kühlerschutz herausnehmen – oben und unten sind kleine Clips.

R&G Racing

Unit 1, Shelley's Lane, East Worldham, Alton, Hampshire, GU34 3AQ

Tel: +44 (0)1420 89007 Fax: +44 (0)1420 87301 [www.rg-racing.com](http://www.rg-racing.com) Email: [info@rg-racing.com](mailto:info@rg-racing.com)



26. Wenn der original Kühlerschutz entfernt wurde, die Kabelbinder (**ARTIKEL 3**) durch den Kühlerschutz (**ARTIKEL 1**) fädeln wie in der Zeichnung Zusammenbau abgebildet.
27. Den jetzt zusammengebauten Kühlerschutz an den Kühler ansetzen und die Kabelbinder um die oberen Halterungen wickeln und befestigen.
28. Um die unteren Kabelbinder zu verbinden, benutzen Sie die Laschen aus Kunststoff an der Innenseite der Verkleidungen, um sie umzuwickeln und befestigen.
29. Sobald alles sicher befestigt ist, können Sie alle Schrauben wieder in die Abdeckungen und Verkleidungen einsetzen. **HINWEIS: der original Kühlerschutz wird nicht angebaut – das Kit ersetzt das Original.**
30. Stellen Sie sicher, dass alle Schrauben ordnungsgemäß fest angezogen sind.

**Klicken Sie hier, um weitere R&G Produkte für Ihr Motorrad zu finden:**

[R&G Racing | Alle Produkte für Aprilia - Tuareg 660 \(2023\) \(rg-racing.com\)](http://www.rg-racing.com)

AUSGABE 1 06/01/2023 – (JH)

#### **CONSUMER NOTICE**

The catalogue description and any exhibition of samples are only broad indications of the Products and R&G may make design changes which do not diminish their performance or visual appeal and supplying them in such state shall conform to the order. The Buyer acknowledges no representation or warranty (other than as to title) has been given or will apply to the Products other than those in R&G's order or confirmation and the Buyer confirms it has chosen the Products as being of merchantable quality and suitable for its particular purposes. Where R&G fits the Products or undertakes other services it shall exercise reasonable skill and care and rectify any fault free of charge unless the workmanship has been disturbed. The Buyer is responsible for ensuring that the warranty on the motorcycle is not affected by the fitting of the Products. On return of any defective Products R&G shall at its option either supply a replacement or refund the purchase money but shall not be liable if the Products have been modified or used or maintained otherwise than in accordance with R&G's or manufacturer's instructions and good engineering practice or if the defect arises from accident or neglect. Other than identified above and subject to R&G not limiting its liability for causing death and personal injury, it shall not be liable for indirect or consequential loss and otherwise its liability shall be limited to the amounts paid by the Buyer for the Products or the fitting or service concerned. These terms do not affect the Buyer's statutory rights.

#### **R&G RACING RETURNS POLICY (NON-FAULTY GOODS)**

Returns must be pre-authorized (if not pre-authorized the return will be rejected). Goods may only be returned direct to us if they were purchased direct from us (customer must prove if necessary). Otherwise to be returned to original vendor. Goods must be in re-sellable condition, in the opinion of R&G Racing. All returns are subject to a 25% restocking and handling fee (25% of the gross value exc. P&P – at the prevailing price at time of purchase). The customer must pay any and all carriage charges. No returns of discontinued products, unless within 14 days of purchase. This policy does not affect your statutory rights and does not refer to faulty goods.

R&G Racing

Unit 1, Shelley's Lane, East Worldham, Alton, Hampshire, GU34 3AQ

Tel: +44 (0)1420 89007 Fax: +44 (0)1420 87301 [www.rg-racing.com](http://www.rg-racing.com) Email: [info@rg-racing.com](mailto:info@rg-racing.com)