

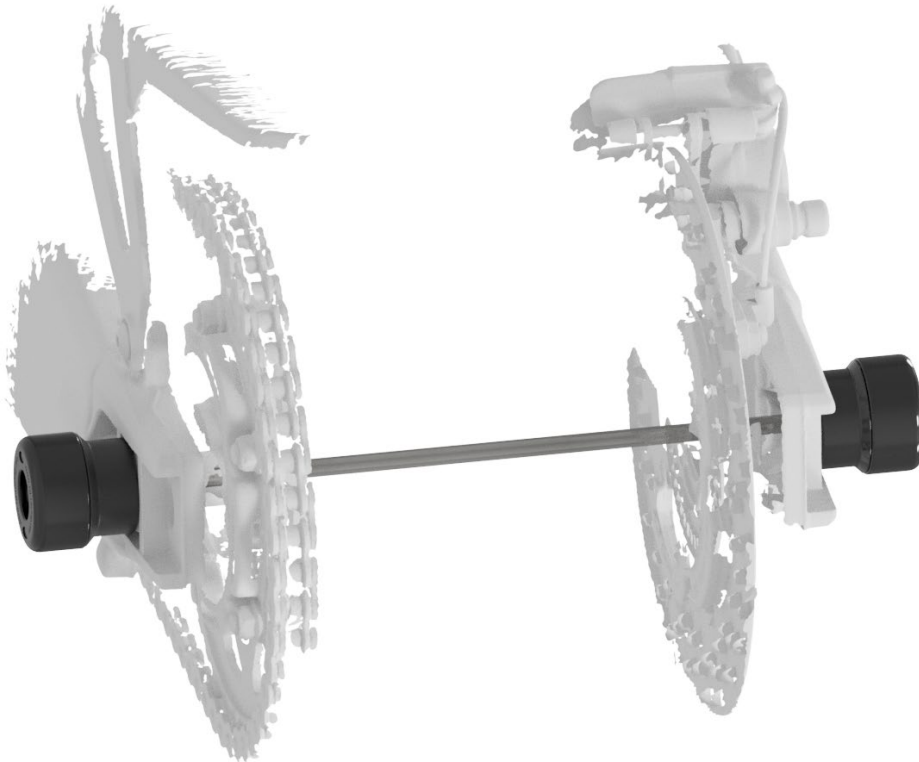

FITTING INSTRUCTIONS FOR SP0095 SWINGARM PROTECTORS



**This kit contains the items pictured and labelled over page.
Some parts may be shown for clarity of instructions only.
Do not proceed until you are sure all parts are present.
Please read all instructions before proceeding.**

**IF IN ANY DOUBT WHEN FITTING OUR PRODUCTS, CONSULT ONE OF OUR DEALERS
OR HAVE FITTED BY A QUALIFIED TECHNICIAN.**

Please note that the way the kit is packed does not necessarily represent the way of mounting to the bike.

In the event of rubber washers being used to hold components onto bolts, these rubber washers can be thrown away.

**DIGITAL COPIES OF THESE INSTRUCTIONS ARE AVAILABLE FROM
WWW.RG-RACING.COM**

R&G
Unit 1, Shelley's Lane, East Worldham, Alton, Hampshire, GU34 3AQ
Tel: +44 (0)1420 89007 Fax: +44 (0)1420 87301 www.rg-racing.com Email: info@rg-racing.com



<u>TOOLS REQUIRED</u>	<u>GENERAL TORQUE SETTINGS</u>
Socket Set to Include 2 x 13mm sockets and wrenches. FAST DRYING SUPER GLUE OR LOCTITE.	M4 BOLT = 8Nm M5 BOLT = 12Nm M6 BOLT = 15Nm M8 BOLT = 20Nm M10 BOLT = 40Nm M12 BOLT = 40Nm

LEGEND

ITEM No.	DESCRIPTION	QTY
ITEM 1	SPINDLE BAR (SB171)	1
ITEM 2	BOBBIN (B0442-M8)	2
ITEM 3	SPACER LHS (S1499)	1
ITEM 4	SPACER RHS (S1498)	1
ITEM 5	M8x19mm WASHER	2
ITEM 6	M8x1.25 NYLOC NUT	2

ASSEMBLY DIAGRAM

VIEWPOINT FROM THE REAR OF THE MOTORCYCLE

LHS

RHS

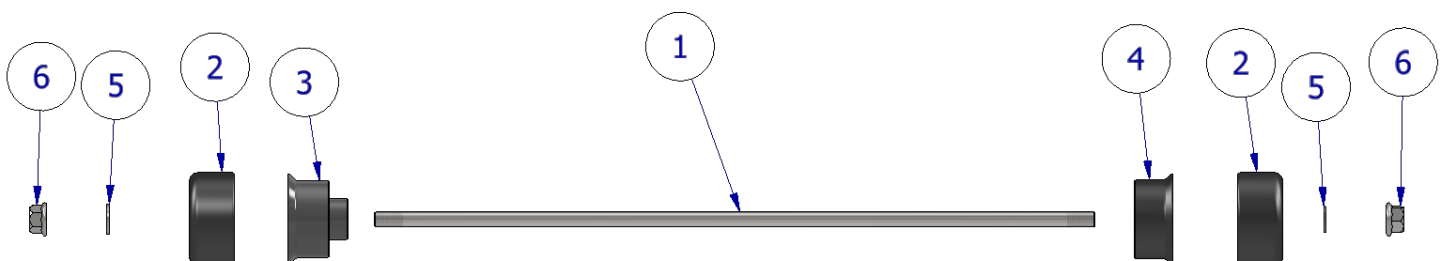

FITTING INSTRUCTIONS

R&G

Unit 1, Shelley's Lane, East Worldham, Alton, Hampshire, GU34 3AQ
Tel: +44 (0)1420 89007 Fax: +44 (0)1420 87301 www.rg-racing.com Email: info@rg-racing.com



1. To start this fitting process, place one of the M8 Nyloc Nuts (**Item 6**) onto one end of the spindle bar (**Item 1**) and tighten it until at least a minimum of 2 threads are through the Nyloc.

A fitting suggestion: using a small amount of Super glue or Loctite on one Spindle bar thread will help create an even number of threads on both sides of the swingarm protector once fully tightened.

2. once the Nyloc is fitted, you can then slide the washer (**Item 5**), bobbin (**Item 2**) and Spacer RHS (**Item 4**) down the bar as shown in the **ASSEMBLY DIAGRAM**.
3. Then slide the half assembly through the righthand side of the rear spindle. Once through place the second Bobbin (**Item 2**), Washer (**Item 5**) onto the spindle bar (**Item 1**) that's poking through the LHS.
4. Then finally place the Nyloc Nut (**ITEM 5**) and tighten to the correct torque using the **GENERAL TORQUE SETTINGS** table on **PAGE 2**.

ISSUE 1 19/10/2023 (MH)

CONSUMER NOTICE

The catalogue description and any exhibition of samples are only broad indications of the Products and R&G may make design changes which do not diminish their performance or visual appeal and supplying them in such state shall conform to the order. The Buyer acknowledges no representation or warranty (other than as to title) has been given or will apply to the Products other than those in R&G's order or confirmation and the Buyer confirms it has chosen the Products as being of merchantable quality and suitable for its particular purposes. Where R&G fits the Products or undertakes other services it shall exercise reasonable skill and care and rectify any fault free of charge unless the workmanship has been disturbed. The Buyer is responsible for ensuring that the warranty on the motorcycle is not affected by the fitting of the Products. On return of any defective Products R&G shall at its option either supply a replacement or refund the purchase money but shall not be liable if the Products have been modified or used or maintained otherwise than in accordance with R&G's or manufacturer's instructions and good engineering practice or if the defect arises from accident or neglect. Other than identified above and subject to R&G not limiting its liability for causing death and personal injury, it shall not be liable for indirect or consequential loss and otherwise its liability shall be limited to the amounts paid by the Buyer for the Products or the fitting or service concerned. These terms do not affect the Buyer's statutory rights.

R&G RACING RETURNS POLICY (NON-FAULTY GOODS)

Returns must be pre-authorized (if not pre-authorized the return will be rejected). Goods may only be returned direct to us if they were purchased direct from us (customer must prove if necessary). Otherwise to be returned to original vendor. Goods must be in re-sellable condition, in the opinion of R&G Racing. All returns are subject to a 25% restocking and handling fee (25% of the gross value exc. P&P – at the prevailing price at time of purchase). The customer must pay any and all carriage charges. No returns of discontinued products, unless within 14 days of purchase. This policy does not affect your statutory rights and does not refer to faulty goods.

R&G

Unit 1, Shelley's Lane, East Worldham, Alton, Hampshire, GU34 3AQ
Tel: +44 (0)1420 89007 Fax: +44 (0)1420 87301 www.rg-racing.com Email: info@rg-racing.com



NOTICE DE MONTAGE POUR SP0095 PROTECTIONS BRAS OSCILLANT

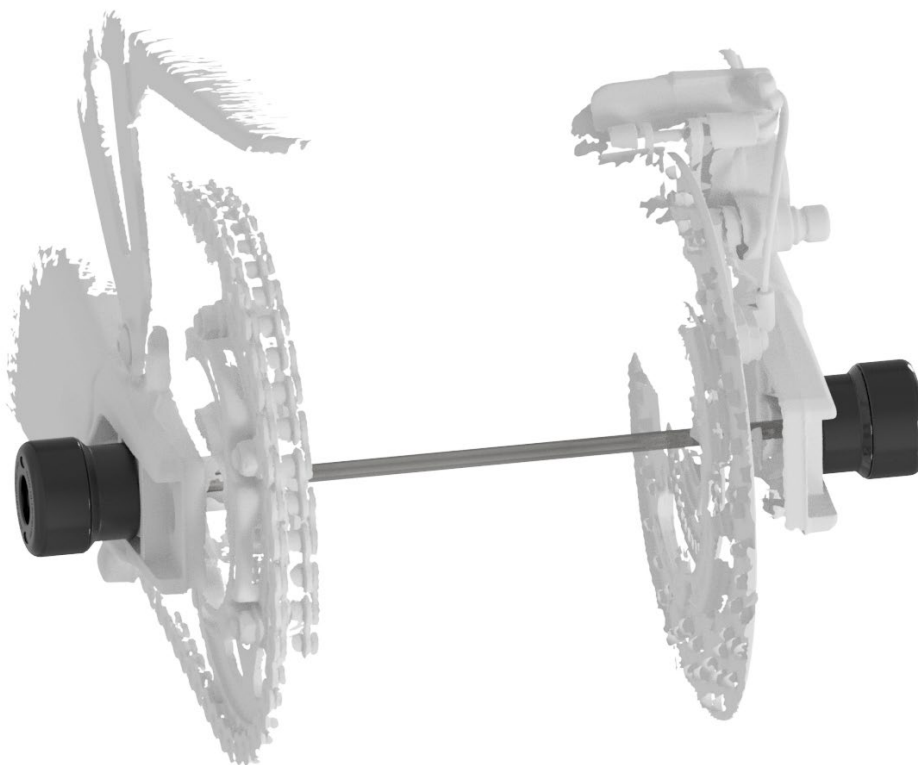

CE KIT CONTIENT LES ARTICLES ILLUSTRÉS ET ÉTIQUETES SUR LA PAGE.

CERTAINES PARTIES PEUVENT ÊTRE PRÉSENTES UNIQUEMENT POUR LA CLARTE DES INSTRUCTIONS.

NE PAS PROCÉDER AU MONTAGE TANT QUE VOUS N'ÊTES PAS SÛR QUE TOUTES LES PIÈCES SOIENT PRÉSENTES.

VEUILLEZ LIRE TOUTES LES INSTRUCTIONS AVANT DE CONTINUER.

EN CAS DE DOUTE LORS DU MONTAGE DE NOS PRODUITS, CONSULTEZ UN DE NOS REVENDEURS OU FAITES APPEL À UN TECHNICIEN QUALIFIÉ.

VEUILLEZ NOTER QUE LA FAÇON DONT LE KIT EST EMBALLÉ NE REPRÉSENTE PAS NECESSAIREMENT LA MANIÈRE DE LE MONTER SUR LA MOTO.

SI DES RONDELLES EN CAOUTCHOUC SONT UTILISÉES POUR MAINTENIR LES COMPOSANTS SUR LES BOULONS, ELLES PEUVENT ÊTRE JETÉES.

NOTICE DISPONIBLE AU TÉLÉCHARGEMENT SUR :

WWW.RG-RACING.COM

R&G

Unit 1, Shelley's Lane, East Worldham, Alton, Hampshire, GU34 3AQ
Tel: +44 (0)1420 89007 Fax: +44 (0)1420 87301 www.rg-racing.com Email: info@rg-racing.com



OUTILS REQUIS	VALEURS DE SERRAGE
<ul style="list-style-type: none"> Clé à cliquet + douilles 2 x 13mm. DE LA SUPER COLLE À SÉCHAGE RAPIDE PEUT ÊTRE UTILE. 	M4 BOULON = 8Nm M5 BOULON = 12Nm M6 BOULON = 15Nm M8 BOULON = 20Nm M10 BOULON = 40Nm M12 BOULON = 40Nm

LÉGENDE

ARTICLE No.	DESCRIPTION	QTÉ
ARTICLE 1	BARRE D'AXE (SB171)	1
ARTICLE 2	BOBBIN (B0442-M8)	2
ARTICLE 3	ENTRETOISE GAUCHE (S1499)	1
ARTICLE 4	ENTRETOISE DROITE (S1498)	1
ARTICLE 5	M8x19mm RONDELLE	2
ARTICLE 6	M8x1.25 ÉCROU	2

SCHÉMA D'ENSEMBLE

POINT DE VUE DEPUIS L'ARRIÈRE DE LA MOTO

GAUCHE

DROITE

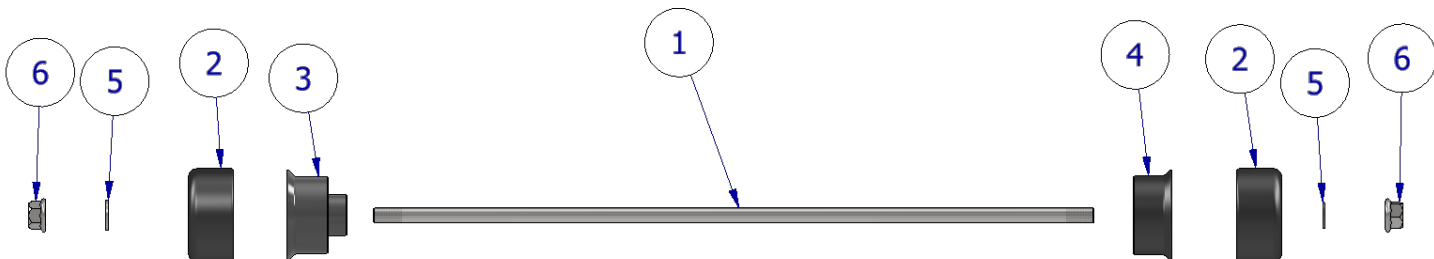

R&G

Unit 1, Shelley's Lane, East Worldham, Alton, Hampshire, GU34 3AQ
 Tel: +44 (0)1420 89007 Fax: +44 (0)1420 87301 www.rg-racing.com Email:
info@rg-racing.com



NOTICE DE MONTAGE

- 1.** Pour démarrer le montage, placez l'écrou Nyloc M8 (**Article 6**) sur l'extrémité M8 de la barre de broche (article 1) et serrez jusqu'à ce qu'au moins 2 filets au moins traversent le Nyloc.

Suggestion de montage : l'utilisation d'une petite quantité de superglue sur un filetage de la barre aidera à créer un nombre pair de filetages des deux côtés de la protection bras oscillant une fois complètement serrée.

- 2.** Une fois le Nyloc monté, vous pouvez ensuite glisser la rondelle (**Article 5**), la protection (**Article 2**) et l'entretoise côté droit (**Article 4**) sur la barre comme indiqué sur le SCHÉMA DE MONTAGE.
- 3.** Faites ensuite glisser l'ensemble par le côté droit de l'axe arrière. Une fois à travers, placez la deuxième protection (**Article 2**), la rondelle (**Article 5**) sur l'axe (**Article 1**) qui passe à travers le côté gauche.
- 4.** Enfin, placez l'écrou (**Article 5**) et serrez au couple correct en utilisant le tableau des RÉGLAGES GÉNÉRAUX DE COUPLE à la PAGE 2.

ISSUE 1 19/10/2023 (MH)