

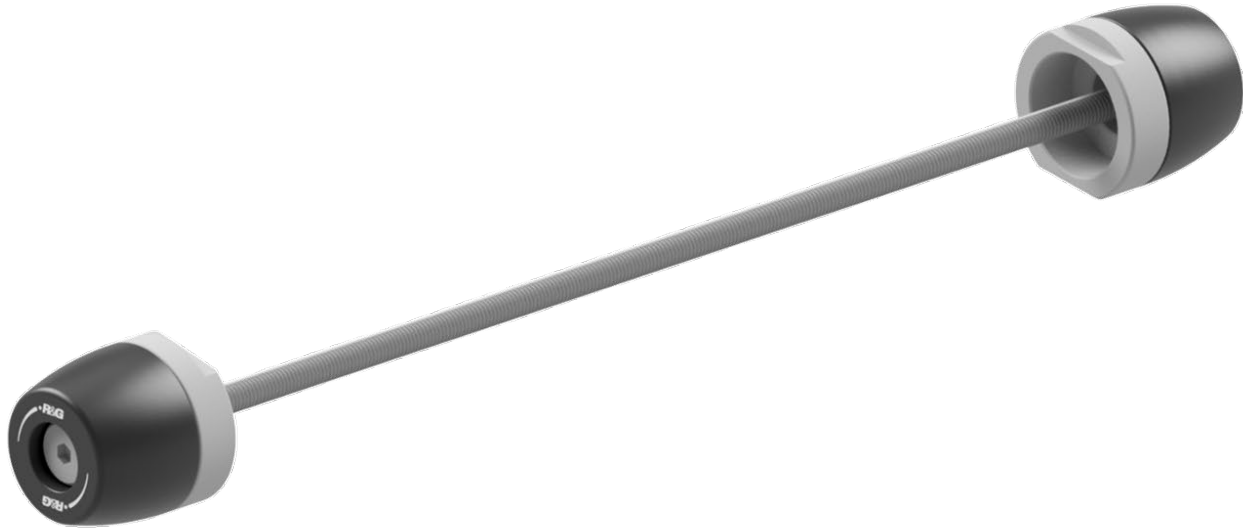

## **FITTING INSTRUCTIONS FOR SP0114 SPINDLE PROTECTORS**



**THIS KIT CONTAINS THE ITEMS PICTURED AND LABELLED OVER PAGE.**

SOME PARTS MAY BE SHOWN FOR CLARITY OF INSTRUCTIONS ONLY.

DO NOT PROCEED UNTIL YOU ARE SURE ALL PARTS ARE PRESENT.

**PLEASE READ ALL INSTRUCTIONS BEFORE PROCEEDING.**

**IF IN ANY DOUBT WHEN FITTING OUR PRODUCTS, CONSULT ONE OF OUR DEALERS OR HAVE FITTED BY A QUALIFIED TECHNICIAN.**

PLEASE NOTE THAT THE WAY THE KIT IS PACKED DOES NOT NECESSARILY REPRESENT THE WAY OF MOUNTING TO THE BIKE.

IN THE EVENT OF RUBBER WASHERS BEING USED TO HOLD COMPONENTS ONTO BOLTS,  
THESE RUBBER WASHERS CAN BE THROWN AWAY.

**DIGITAL COPIES OF THESE INSTRUCTIONS ARE AVAILABLE FROM:**

[WWW.RG-RACING.COM](http://WWW.RG-RACING.COM)

Racing Technique Ltd T/A R&G  
Unit 1, Shelley's Lane, East Worldham, Alton, Hampshire, GU34 3AQ  
Tel: +44 (0)1420 89007 [www.rg-racing.com](http://www.rg-racing.com) Email: [info@rg-racing.com](mailto:info@rg-racing.com)



<b><u>TOOLS REQUIRED</u></b>	<b><u>GENERAL TORQUE SETTINGS</u></b>
5mm Allen Key x 2 Small amount of super glue	M4 BOLT = 8Nm M5 BOLT = 12Nm M6 BOLT = 15Nm M8 BOLT = 20Nm M10 BOLT = 40Nm M12 BOLT = 40Nm

### **LEGEND**

<b>ITEM NO.</b>	<b>DESCRIPTION</b>	<b>QTY</b>
ITEM 1	SB182 SPINDLE BAR	1
ITEM 2	B0575 - CRASH BOBBINS	2
ITEM 3	S1600 - LHS SPACER	1
ITEM 4	S1601 - RHS SPACER	1
ITEM 5	M8 BARREL NUT	2

### **ASSEMBLY DIAGRAM**

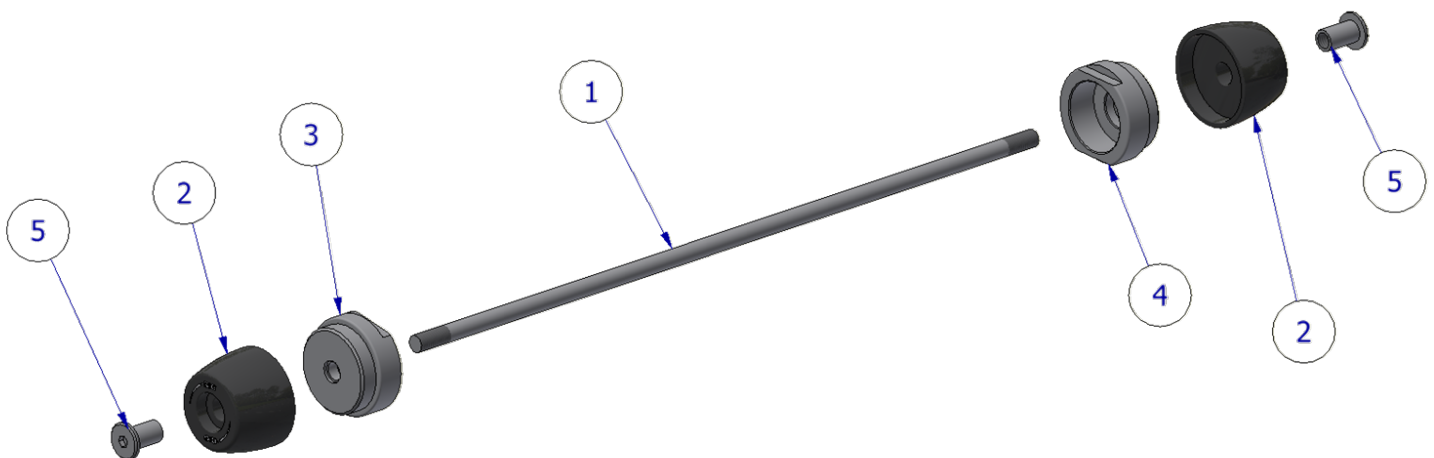



## **FITTING INSTRUCTIONS**

- To start this fitting process, place one barrel nut (**Item 5**) onto the end of the spindle bar (**Item 1**) and tighten until at least half of the spindle bar thread is inside the barrel nut.
- A fitting suggestion: using a small amount of Loctite on the Spindle bar thread will help create an even number of threads on both sides of the swingarm protector once fully tightened.
- Now slide one crash protector bung (**Item 2**) and RHS Spacer (**Item 4**) onto the bar in the configuration shown in the ASSEMBLY DIAGRAM.
- Slide the assembly through the RHS of the rear spindle. Once through place the LHS Spacer (**Item 3**) and remaining crash protector bung (**Item 2**) onto the end of the spindle bar that's protruding through the LHS. NOTE – Please ensure the cutouts on each spacer align with the swingarm.
- Finally, place the second barrel nut (**Item 5**) over the exposed end of the spindle bar and tighten with two 5mm Allen keys simultaneously to the correct torque using the **GENERAL TORQUE SETTINGS** table on **PAGE 2**.

ISSUE 1 – 13/02/2025 (MH)

### **CONSUMER NOTICE**

The catalogue description and any exhibition of samples are only broad indications of the Products and R&G may make design changes which do not diminish their performance or visual appeal and supplying them in such state shall conform to the order. The Buyer acknowledges no representation or warranty (other than as to title) has been given or will apply to the Products other than those in R&G's order or confirmation and the Buyer confirms it has chosen the Products as being of merchantable quality and suitable for its particular purposes. Where R&G fits the Products or undertakes other services it shall exercise reasonable skill and care and rectify any fault free of charge unless the workmanship has been disturbed. The Buyer is responsible for ensuring that the warranty on the motorcycle is not affected by the fitting of the Products. On return of any defective Products R&G shall at its option either supply a replacement or refund the purchase money but shall not be liable if the Products have been modified or used or maintained otherwise than in accordance with R&G's or manufacturer's instructions and good engineering practice or if the defect arises from accident or neglect. Other than identified above and subject to R&G not limiting its liability for causing death and personal injury, it shall not be liable for indirect or consequential loss and otherwise its liability shall be limited to the amounts paid by the Buyer for the Products or the fitting or service concerned. These terms do not affect the Buyer's statutory rights.

### **R&G RACING RETURNS POLICY (NON-FAULTY GOODS)**

Returns must be pre-authorized (if not pre-authorized the return will be rejected). Goods may only be returned direct to us if they were purchased direct from us (customer must prove if necessary). Otherwise to be returned to original vendor. Goods must be in re-sellable condition, in the opinion of R&G Racing. All returns are subject to a 25% restocking and handling fee (25% of the gross value exc. P&P – at the prevailing price at time of purchase). The customer must pay any and all carriage charges. No returns of discontinued products, unless within 14 days of purchase. This policy does not affect your statutory rights and does not refer to faulty goods.



## **NOTICE DE MONTAGE POUR SP0114 PROTECTIONS BRAS OSCILLANT**

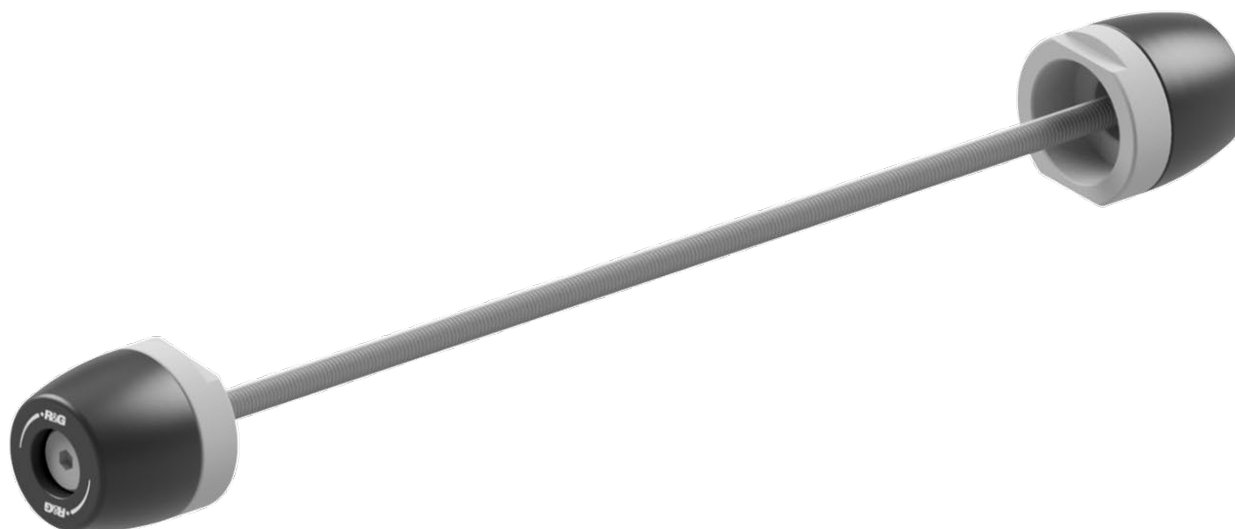

**CE KIT CONTIENT LES ARTICLES ILLUSTRÉS ET ÉTIQUETES SUR LA PAGE.**

CERTAINES PARTIES PEUVENT ÊTRE PRÉSENTES UNIQUEMENT POUR LA CLARTE DES INSTRUCTIONS.

NE PAS PROCÉDER AU MONTAGE TANT QUE VOUS N'ÊTES PAS SÛR QUE TOUTES LES PIÈCES SOIENT PRÉSENTES.

**VEUILLEZ LIRE TOUTES LES INSTRUCTIONS AVANT DE CONTINUER.**

**EN CAS DE DOUTE LORS DU MONTAGE DE NOS PRODUITS, CONSULTEZ UN DE NOS  
REVENDEURS OU FAITES APPEL À UN TECHNICIEN QUALIFIÉ.**

VEUILLEZ NOTER QUE LA FAÇON DONT LE KIT EST EMBALLÉ NE REPRÉSENTE PAS NECESSAIREMENT LA MANIÈRE DE LE  
MONTER SUR LA MOTO.

SI DES RONDELLES EN CAOUTCHOUC SONT UTILISÉES POUR MAINTENIR LES COMPOSANTS SUR LES BOULONS, ELLES  
PEUVENT ÊTRE JETÉES.

**NOTICE DISPONIBLE AU TÉLÉCHARGEMENT SUR :**  
[WWW.RG-RACING.COM](http://WWW.RG-RACING.COM)



<b><u>OUTILS REQUIS</u></b>	<b><u>VALEURS DE SERRAGE</u></b>
Clés Allen 5mm x2	M4 BOULON = 8Nm
Un peu de superglue	M5 BOULON = 12Nm
	M6 BOULON = 15Nm
	M8 BOULON = 20Nm
	M10 BOULON = 40Nm
	M12 BOULON = 40Nm

### **LÉGENDE**

<b>ARTICLE NO.</b>	<b>DESCRIPTION</b>	<b>QTÉ</b>
ARTICLE 1	SB182 BARRE D'AXE	1
ARTICLE 2	B0575 - PROTECTIONS CRASH	2
ARTICLE 3	S1600 - ENTRETOISE GAUCHE	1
ARTICLE 4	S1601 - ENTRETOISE DROITE	1
ARTICLE 5	M8 ÉCROU À BARILLET	2

### **SCHÉMA D'ENSEMBLE**

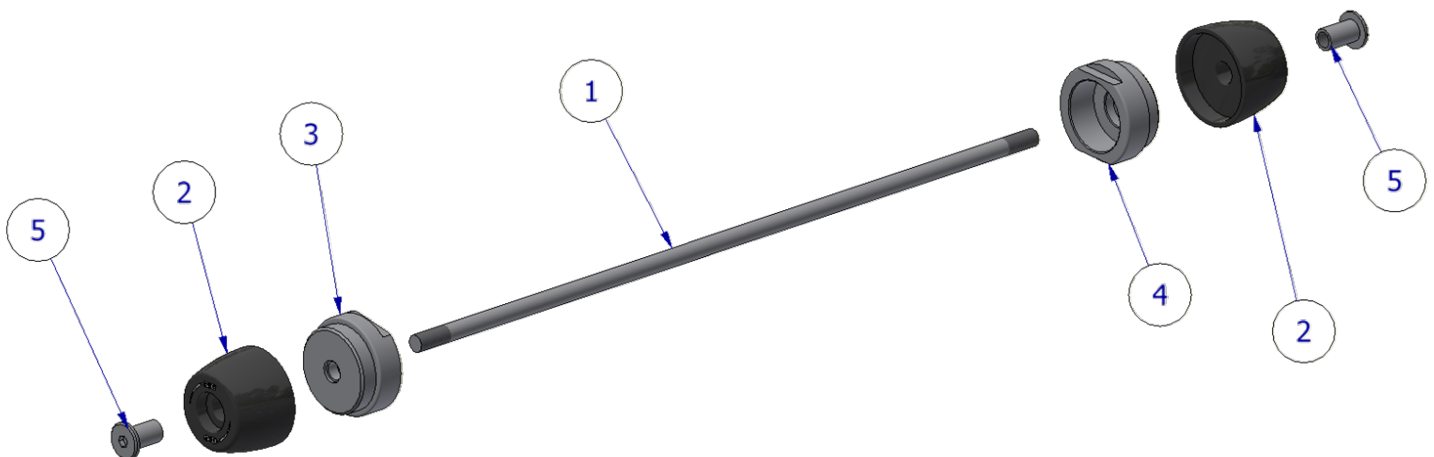



## NOTICE DE MONTAGE

- Pour commencer ce processus de montage, placez un écrou cylindrique (article 5) sur l'extrémité de la barre (article 1) et serrez jusqu'à ce qu'au moins la moitié du filetage de la barre soit à l'intérieur de l'écrou cylindrique.
- Suggestion de montage : l'utilisation d'une petite quantité de Loctite sur le filetage de la barre aidera à créer un nombre pair de filetages des deux côtés de la protection bras oscillant une fois complètement serré.
- Faites maintenant glisser un bouchon de protection crash (article 2) et une entretoise côté droit (article 4) sur la barre dans la configuration indiquée sur le SCHÉMA D'ASSEMBLAGE.
- Faites glisser l'assemblage à travers le côté droit de la broche arrière. Une fois à travers, placez l'entretoise gauche (article 3) et le bouchon de protection crash restant (article 2) sur l'extrémité de la barre qui dépasse à travers le côté gauche.

**REMARQUE** - Veuillez vous assurer que les découpes de chaque entretoise s'alignent avec le bras oscillant.

- Enfin, placez le deuxième écrou cylindrique (article 5) sur l'extrémité exposée de la barre et serrez avec deux clés Allen de 5mm simultanément au couple correct en utilisant le tableau RÉGLAGES DE COUPLE GÉNÉRAUX à la PAGE 2.

ISSUE 1 – 13/02/2025 (MH)

### **CONSUMER NOTICE**

The catalogue description and any exhibition of samples are only broad indications of the Products and R&G may make design changes which do not diminish their performance or visual appeal and supplying them in such state shall conform to the order. The Buyer acknowledges no representation or warranty (other than as to title) has been given or will apply to the Products other than those in R&G's order or confirmation and the Buyer confirms it has chosen the Products as being of merchantable quality and suitable for its particular purposes. Where R&G fits the Products or undertakes other services it shall exercise reasonable skill and care and rectify any fault free of charge unless the workmanship has been disturbed. The Buyer is responsible for ensuring that the warranty on the motorcycle is not affected by the fitting of the Products. On return of any defective Products R&G shall at its option either supply a replacement or refund the purchase money but shall not be liable if the Products have been modified or used or maintained otherwise than in accordance with R&G's or manufacturer's instructions and good engineering practice or if the defect arises from accident or neglect. Other than identified above and subject to R&G not limiting its liability for causing death and personal injury, it shall not be liable for indirect or consequential loss and otherwise its liability shall be limited to the amounts paid by the Buyer for the Products or the fitting or service concerned. These terms do not affect the Buyer's statutory rights.

### **R&G RACING RETURNS POLICY (NON-FAULTY GOODS)**

Returns must be pre-authorized (if not pre-authorized the return will be rejected). Goods may only be returned direct to us if they were purchased direct from us (customer must prove if necessary). Otherwise to be returned to original vendor. Goods must be in re-sellable condition, in the opinion of R&G Racing. All returns are subject to a 25% restocking and handling fee (25% of the gross value exc. P&P – at the prevailing price at time of purchase). The customer must pay any and all carriage charges. No returns of discontinued products, unless within 14 days of purchase. This policy does not affect your statutory rights and does not refer to faulty goods.