

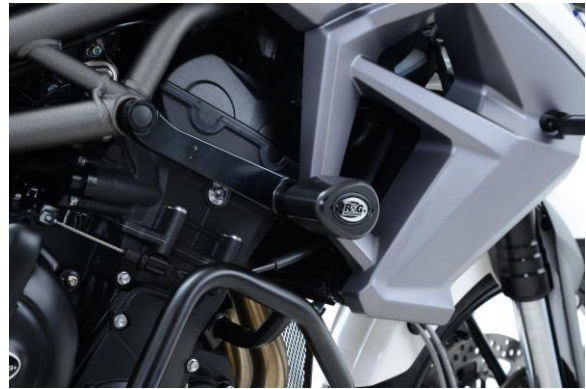

FITTING INSTRUCTIONS FOR CP0387BL
AERO CRASH PROTECTORS
TRIUMPH TIGER 800 XRX/ 800XCX 2015-



Picture A



Picture B

THIS KIT CONTAINS THE ITEMS PICTURED AND LABELLED BELOW.
DO NOT PROCEED UNTIL YOU ARE SURE ALL PARTS ARE PRESENT.

Please note that the way the kit is packed does not necessarily represent the way of mounting to the bike

THE PARTS SHOWN MAY BE REPRESENTATIVE ONLY (FOR CLARITY OF INSTRUCTIONS ONLY)

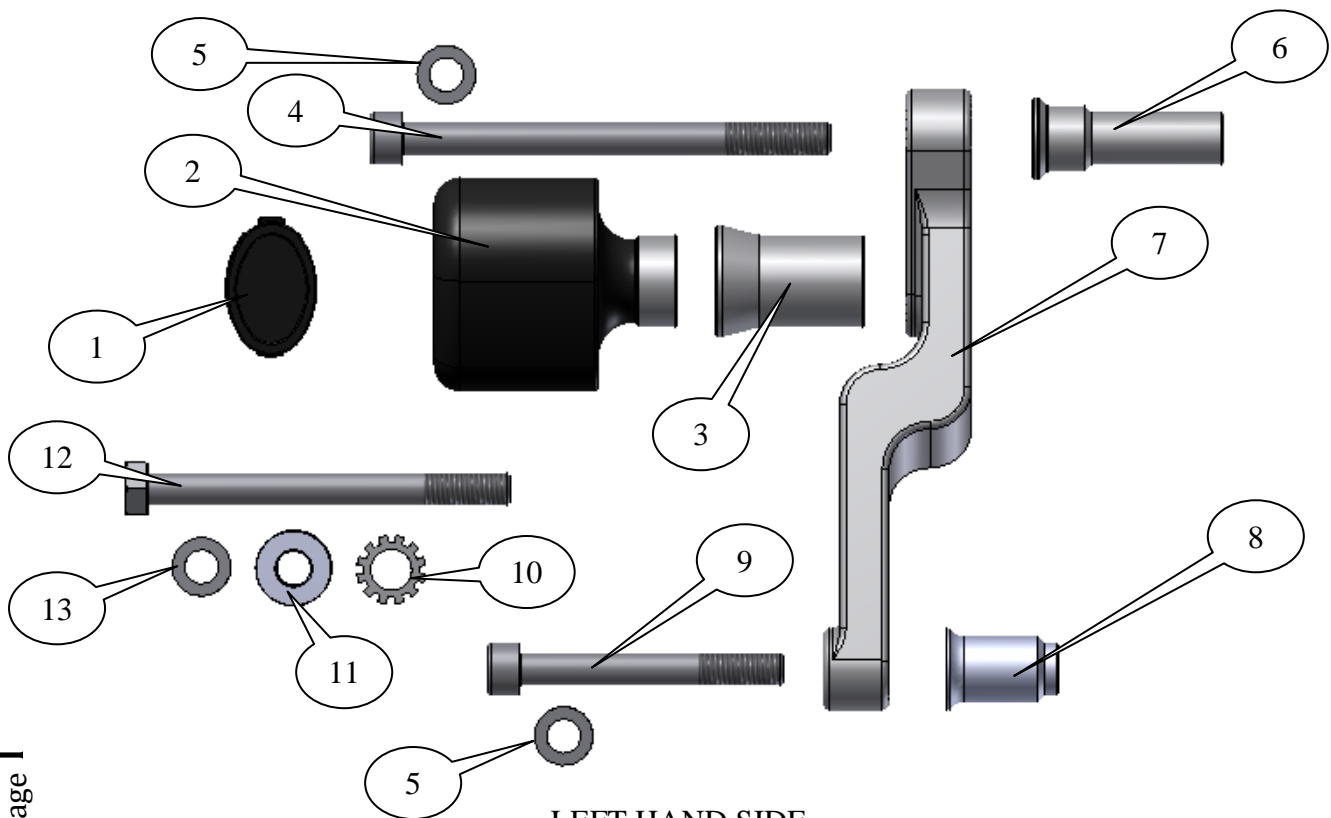

LEFT HAND SIDE

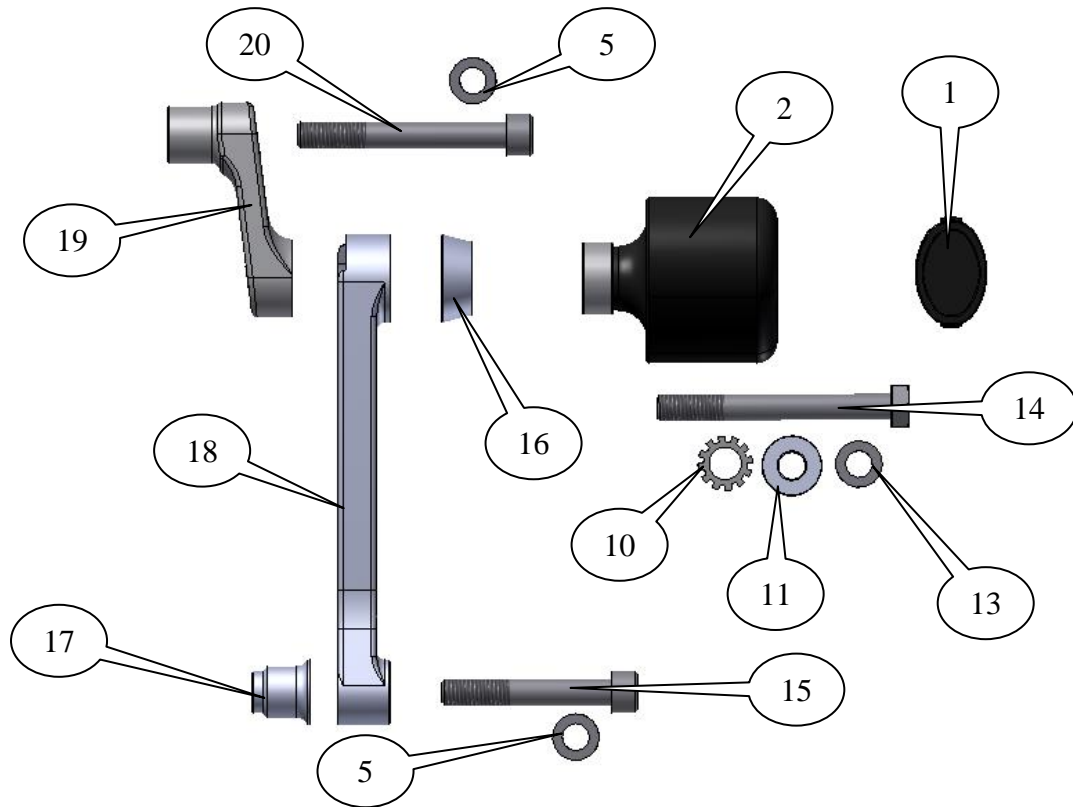

RIGHT HAND SIDE

LEGEND

- ITEM 1 = CRASH PROTECTOR CAPS (BC0002) (x2).
 ITEM 2 = CRASH PROTECTOR (B0431 with CS341) (x2).
 ITEM 3 = SPACER (S0873-45mm long) (LHS PROTECTOR) (x1).
 ITEM 4 = M10x1.25x130mm LONG CAP HEAD BOLT (x1).
 ITEM 5 = M10 WASHERS (16mm O/DIA) (MOUNTING BLOCKS) (x4).
 ITEM 6 = SPACER (S0872-58mm long) (LHS FRONT) (x1).
 ITEM 7 = LEFT MOUNTING BLOCK (M0437) (x1).
 ITEM 8 = SPACER (S0753) (34mm long) (x1).
 ITEM 9 = M10x1.25x80mm LONG CAP HEAD BOLT (LHS REAR) (x1).
 ITEM 10 = LOCK-WASHERS (LW0001) (x2).
 ITEM 11 = INSIDE CRASH PROTECTOR SPACER (S0727) (5mm WIDE) (x2).
 ITEM 12 = M10x1.25x110mm LONG HEX HEAD BOLT (LHS PROTECTOR) (x1).
 ITEM 13 = M10 WASHERS (19mm OD) (PROTECTORS) (x2).
 ITEM 14 = M10x1.25x90mm LONG HEX HEAD BOLT (x1).
 ITEM 15 = M10x1.25x65mm LONG CAP HEAD BOLT (RHS REAR) (x1).
 ITEM 16 = SPACER (S0778-12mm long) (RHS PROTECTOR) (x1).
 ITEM 17 = SPACER (S0755-22.5mm long) (RHS REAR) (x1).
 ITEM 18 = RIGHT MOUNTING BLOCK REAR (M0388) (x1).
 ITEM 19 = RIGHT MOUNTING BLOCK FRONT (M0387) (x1).
 ITEM 20 = M10x1.25x80mm LONG CAP HEAD BOLT (RHS FRONT) (x1).
 ITEM 21 = M10 CAP HEAD BOLT PLASTIC CAP (x4) (NOT SHOWN ABOVE).



Please note that in cases where kits are packed with rubber washers holding the components onto the bolt – *the rubber washers should be thrown away!*

TOOLS REQUIRED

- Socket set to include 5 & 8mm A/F socket and wrench.
- Socket set to include 14 & 17mm socket and wrench.
 - Long socket extensions.
 - T50 Torx Socket.
 - 8 & 14mm spanners.
- Torque wrench (up to 40Nm).

TOWARDS REAR
OF BIKE

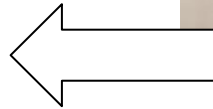

TOWARDS FRONT
OF BIKE

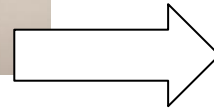

PICTURE C



PICTURE 1



PICTURE 2



PICTURE 3

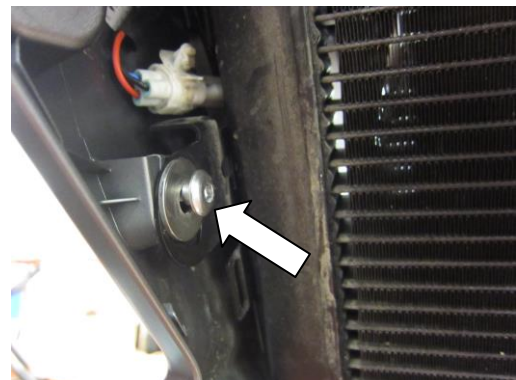

PICTURE 4

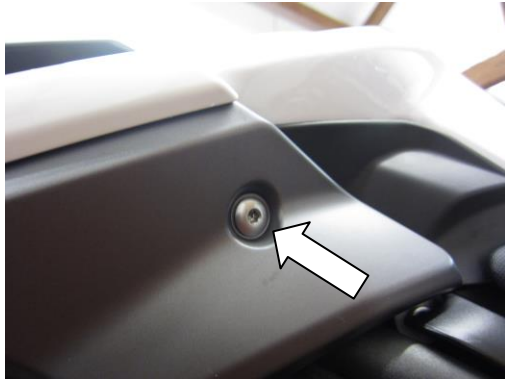

PICTURE 5



PICTURE 6

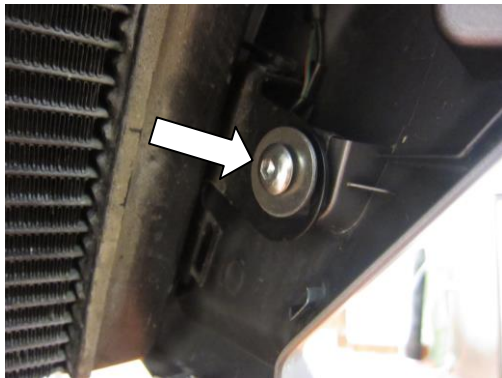

PICTURE 7



PICTURE 8

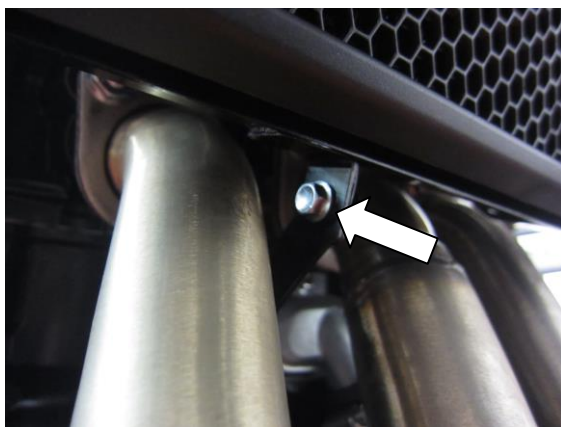

Picture 9



Picture 10



Picture 11



Picture 12

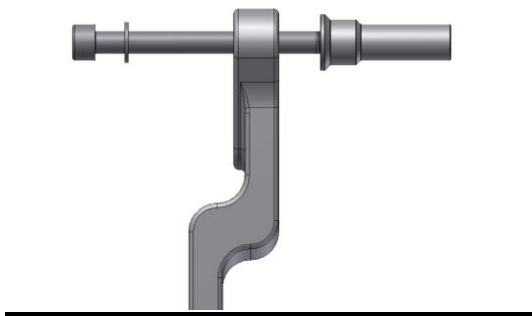

Picture 13



Picture 14



Picture 15



Picture 16

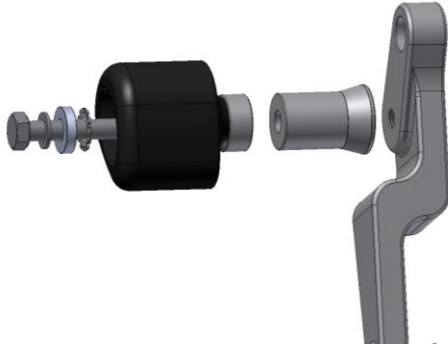

Picture 17



Picture 18



Picture 19



Picture 20



Picture 21



Picture 22



Picture 23



Picture 24

FITTING INSTRUCTIONS

Left Side (as you sit on the bike)

- Remove the radiator side fairings from both sides of the bike. To do this remove the bolts and plastic push rivet's as shown in pictures 1 to 8 and disconnect the indicator wiring plug sockets.
- Remove the bolt which secures the bottom of the radiator in place, as shown in picture 9.
- Remove the bolt which secures the top of the radiator in place, as shown in picture 10.
- This should allow the radiator to tilt forward giving more accessibility, as shown in picture 11.
- Remove the front engine/frame bolt on the left side of the bike, as shown in picture 12. *There is a nut on the rear of this bolt which can either be accessed by a 14mm spanner from underneath or a 14mm socket with long extension from the other side of the bike.* There will also be a spacer which will drop out. This will need to be re-fitted when fitting the crash protector kit and sits between the frame and engine.
- Fit one of the smaller M10 washers (item 5) onto the M10 x 1.25 x 130mm long cap head bolt (item 4) and position through the front mounting hole of the left side metal block (item 7 – M0437). Place the longer spacer (item 6 – S0872 – 58mm long) over the exposed end of the thread with the larger diameter end sitting against the metal block, as shown in picture 13.
- Offer this assembly up to the bike, ensuring the protruding thread on the bolt locates through the front engine/frame boss, taking care to re-fit the OEM spacer during installation. Once in place, re-fit the OEM nut to the end of the bolt and loosely tighten, as shown in picture 14.
- Remove the rear engine/frame bolt on the left side of the bike as shown in picture 15. *There will be another spacer which will drop out which will need to be re-used.*
- Locate the spacer (item 8 – S0753 – 34mm long) into the frame boss and move the mounting block into place over the top, ensuring the holes align.
- Fit one M10 washer (item 5) onto the M10 x 1.25 x 80mm long cap head bolt (item 9) and position through the rear mounting hole of the left side metal block, then through the spacer into the frame/engine mount, ensuring the OEM spacer is re-fitted in between the frame and engine, before loosely tightening, as shown in picture 14.
- These two engine/frame bolts can now be tightened to the manufacturers recommended torque settings and fitted with the plastic caps (item 21).

R&G Racing

Unit 1, Shelley's Lane, East Worldham, Alton, Hampshire, GU34 3AQ

Tel: +44 (0)1420 89007 Fax: +44 (0)1420 87301 www.rg-racing.com Email: info@rg-racing.com



- The crash protector can now be fitted. Slide one of the larger M10 washers (item 13) onto the M10 x 1.25 x 110mm long hex head bolt (item 12) so the washer sits against head of bolt.
- Slide one of the smaller spacers (item 11-5mm wide) over the bolt so it sits against the washer just fitted.
- Slide one serrated locking washer (item 10) over the bolt so it sits against the spacer just fitted.
- Next slide the bolt with washers through either crash protector (item 2) so head of bolt and washers goes into counter-bore in the crash protector, then into the longer chamfered spacer (item 3 – S0873 – 45mm long) with the smaller diameter against the crash protector as shown in picture 17.
- Offer the crash protector up to the mounting block and tighten the bolt, as shown in pictures 17 & 18.
- Tighten the bolt until you feel some compression from inside the protector using a 17mm socket and wrench. **PLEASE NOTE THE CRASH PROTECTOR MUST BE POSITIONED AS IN PICTURE ‘C’ WITH BIGGER END TOWARD FRONT OF BIKE.** Turn a little more so that you feel the compression increase slightly. Then apply a quarter turn. Do not over tighten as damage can occur to the bike. Do not exceed 40nm of torque.

Right Side (as you sit on the bike)

- Remove the front engine/frame bolt on the right side of the bike, as shown in picture 19. *There is a nut on the rear of this bolt which can either be accessed by a 14mm socket with long extension from the other side of the bike.*
- Fit one of the smaller M10 washers (item 5) onto the M10 x 1.25 x 80mm long cap head bolt (item 20) and position through the recessed mounting hole of the right side metal front block (item 19 – M0438).
- Offer this assembly up to the bike, ensuring the protruding thread on the bolt locates through the front engine/frame boss. Once in place, re-fit the OEM nut to the end of the bolt and loosely tighten, as shown in picture 19.
- Remove the rear engine/frame bolt on the right side of the bike as shown in picture 20.
- Fit one of the smaller M10 washers (item 5) onto the M10 x 1.25 x 65mm long cap head bolt (item 15) and position through the mounting hole of the right side metal rear block (item 18 – M0388), then through the remaining spacer (item 17 – S0755 – 22.5mm long) and into the frame/engine mount, before loosely tightening, as shown in picture 21.
- The two blocks can now be aligned on the bike so that the hole on the top block aligns with the threaded boss on the block behind. There is also a machined recess on the rear of the top block which will sit around the rear block as shown in picture 22.
- The crash protector can now be fitted. Slide one of the larger 10mm washers (item 13) onto the M10 x 1.25 x 90mm long hex head bolt (item 14) so the washer sits against head of bolt.
- Slide one of the smaller spacers (item 11-5mm wide) over the bolt so it sits against the washer just fitted.
- Slide one of the serrated locking washer (item 10) over the bolt so it sits against the spacer just fitted.
- Next slide the bolt with washers through either crash protector (item 2) so head of bolt and washers goes into counter-bore in bobbin then over the shorter chamfered spacer (item 16 – S0778 – 12mm long). Offer the crash protector up to the mounting block and tighten the bolt, as shown in pictures 23 & 24.
- Tighten the bolt until you feel some compression from inside the protector using a 17mm socket and wrench. **PLEASE NOTE THE CRASH PROTECTOR MUST BE**



POSITIONED AS IN PICTURE 'C' WITH BIGGER END TOWARD FRONT OF BIKE. Turn a little more so that you feel the compression increase slightly. Then apply a quarter turn. Do not over tighten as damage can occur to the bike. Do not exceed 40Nm of torque.

- The two engine/frame bolts can now be tightened to the manufacturers recommended torque settings and fitted with the plastic caps (item 21).
- Re-fit the two bolts that secure the radiator in place as original.
- Re-fit both the plastic radiator cowling in place and reconnect the indicators as original.
- Ensure the fairings are correctly fitted with all bolts fully tightened.
- If not already fitted fit bubble stickers into recess of both crash protector caps.
- Fit crash protector caps into both crash protectors.

ISSUE 1 12/05/2015 (NSY)

CONSUMER NOTICE

The catalogue description and any exhibition of samples are only broad indications of the Products and R&G may make design changes which do not diminish their performance or visual appeal and supplying them in such state shall conform to the order. The Buyer acknowledges no representation or warranty (other than as to title) has been given or will apply to the Products other than those in R&G's order or confirmation and the Buyer confirms it has chosen the Products as being of merchantable quality and suitable for its particular purposes. Where R&G fits the Products or undertakes other services it shall exercise reasonable skill and care and rectify any fault free of charge unless the workmanship has been disturbed. The Buyer is responsible for ensuring that the warranty on the motorcycle is not affected by the fitting of the Products. On return of any defective Products R&G shall at its option either supply a replacement or refund the purchase money but shall not be liable if the Products have been modified or used or maintained otherwise than in accordance with R&G's or manufacturer's instructions and good engineering practice or if the defect arises from accident or neglect. Other than identified above and subject to R&G not limiting its liability for causing death and personal injury, it shall not be liable for indirect or consequential loss and otherwise its liability shall be limited to the amounts paid by the Buyer for the Products or the fitting or service concerned. These terms do not affect the Buyer's statutory rights.

R&G RACING RETURNS POLICY (NON-FAULTY GOODS)

Returns must be pre-authorized (if not pre-authorized the return will be rejected). Goods may only be returned direct to us if they were purchased direct from us (customer must prove if necessary). Otherwise to be returned to original vendor. Goods must be in re-sellable condition, in the opinion of R&G Racing. All returns are subject to a 25% restocking and handling fee (25% of the gross value exc. P&P – at the prevailing price at time of purchase). The customer must pay any and all carriage charges. No returns of discontinued products, unless within 14 days of purchase. This policy does not affect your statutory rights and does not refer to faulty goods.

Digital copies of these instructions are available to download from www.rg-racing.com

- **GENERAL TORQUE SETTINGS**
 - M4 BOLT = 8Nm
 - M5 BOLT = 12Nm
 - M6 BOLT = 15Nm
 - M8 BOLT = 20Nm
 - M10 BOLT = 40Nm
 - M10 NYLOC NUT = 40Nm

CONSUMER NOTICE

The catalogue description and any exhibition of samples are only broad indications of the Products and R&G may make design changes which do not diminish their performance or visual appeal and supplying them in such state shall conform to the order. The Buyer acknowledges no representation or warranty (other than as to title) has been given or will apply to the Products other than those in R&G's order or confirmation and the Buyer confirms it has chosen the Products as being of merchantable quality and suitable for its particular purposes. Where R&G fits the Products or undertakes other services it shall exercise reasonable skill and care and rectify any fault free of charge unless the workmanship has been disturbed. The Buyer is responsible for ensuring that the warranty on the motorcycle is not affected by the fitting of the Products. On return of any defective Products R&G shall at its option either supply a replacement or refund the purchase money but shall not be liable if the Products have been modified or used or maintained otherwise than in accordance with R&G's or manufacturer's instructions and good engineering practice or if the defect arises from accident or neglect. Other than identified above and subject to R&G not limiting

R&G Racing

Unit 1, Shelley's Lane, East Worldham, Alton, Hampshire, GU34 3AQ

Tel: +44 (0)1420 89007 Fax: +44 (0)1420 87301 www.rg-racing.com Email: info@rg-racing.com



its liability for causing death and personal injury, it shall not be liable for indirect or consequential loss and otherwise its liability shall be limited to the amounts paid by the Buyer for the Products or the fitting or service concerned. These terms do not affect the Buyer's statutory rights.

R&G RACING RETURNS POLICY (NON-FAULTY GOODS)

Returns must be pre-authorized (if not pre-authorized the return will be rejected). Goods may only be returned direct to us if they were purchased direct from us (customer must prove if necessary). Otherwise to be returned to original vendor. Goods must be in re-sellable condition, in the opinion of R&G Racing. All returns are subject to a 25% restocking and handling fee (25% of the gross value exc. P&P – at the prevailing price at time of purchase). The customer must pay any and all carriage charges. No returns of discontinued products, unless within 14 days of purchase. This policy does not affect your statutory rights and does not refer to faulty goods.



INSTRUCTIONS DE MONTAGE POUR CP0387BL
PROTECTIONS CRASH
TRIUMPH TIGER 800 XRX/ 800XCX 2015-



Photo A

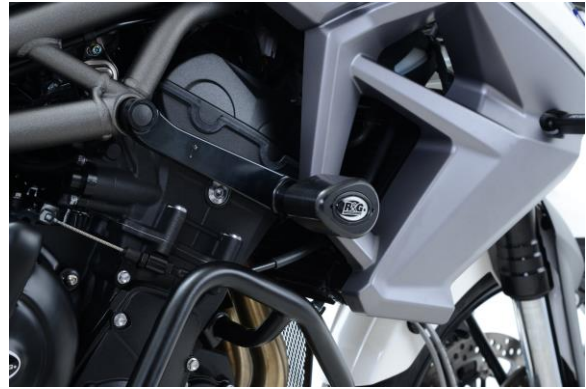
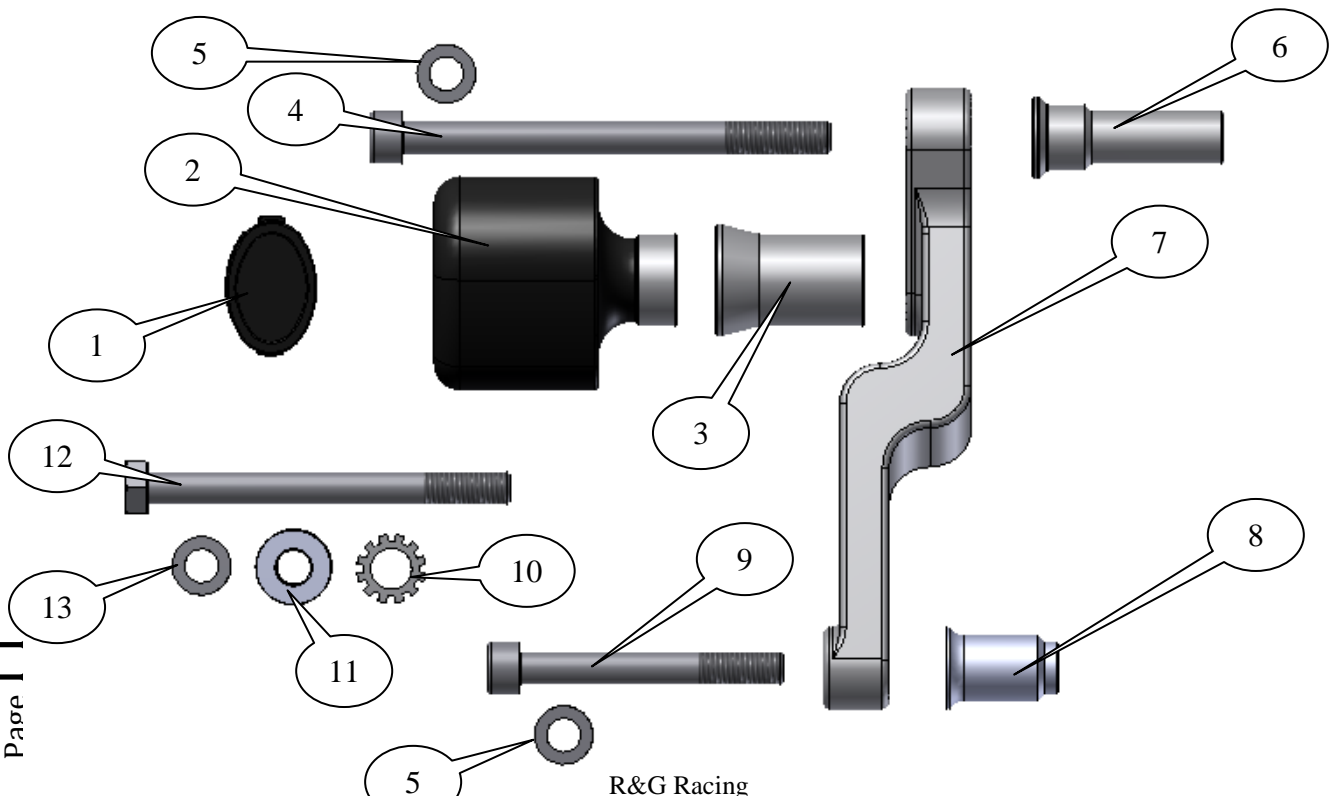

Photo B

LE KIT CONTIENT LES ARTICLES EXPOSES CI-DESSOUS, VERIFIER QUE TOUTES LES PIECES SOIENT PRESENTES AVANT DE PROCEDER AU MONTAGE.

LA FAÇON DONT LE KIT EST EMBALLE NE CORRESPOND PAS FORCEMENT A LA FAÇON DE MONTER LES PIECES SUR LA MOTO.

LES PARTIES PRESENTEES PEUVENT ETRE UNIQUEMENT REPRESENTATIVES (POUR LA CLARTE DES INSTRUCTIONS UNIQUEMENT).



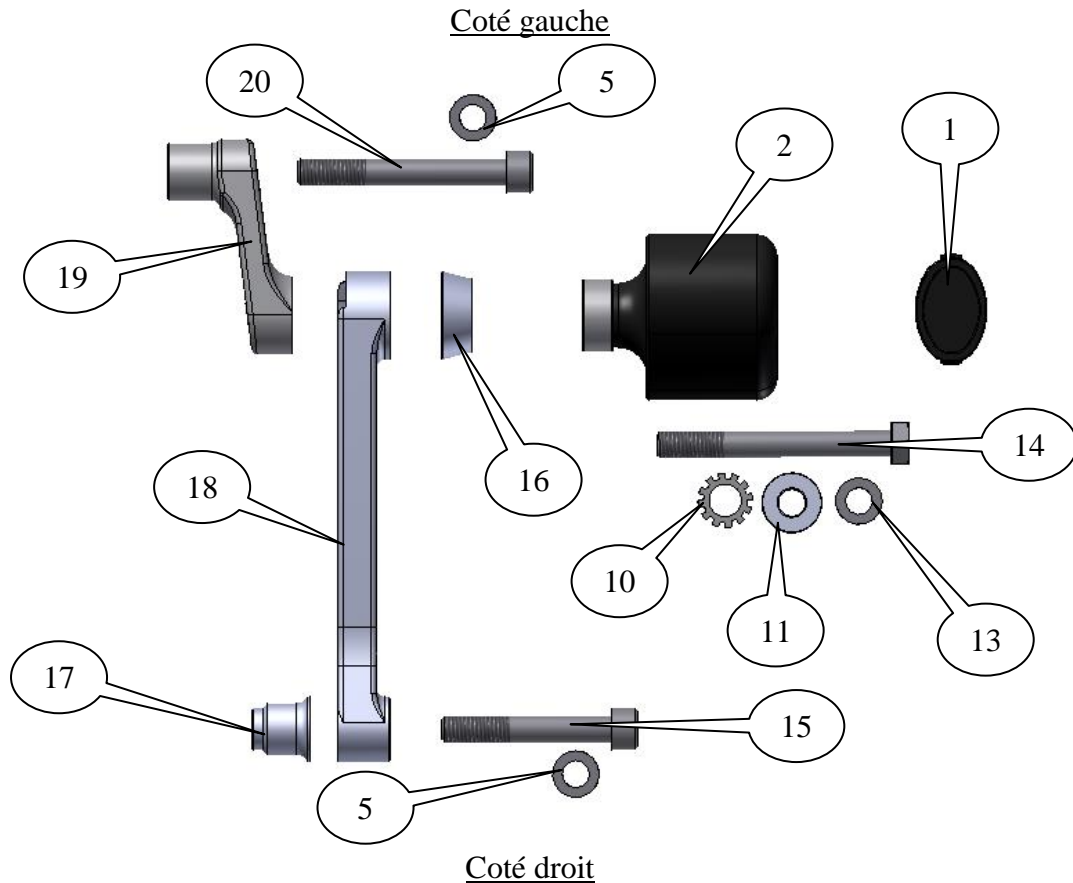

LEGENDE

- ARTICLE 1 = CAPUCHONS DE PROTECTION CRASH (BC0002) (x2).
 ARTICLE 2 = PROTECTION CRASH (B0431 avec CS341) (x2).
 ARTICLE 3 = ENTRETOISE (S0873-45mm de long) (PROTECTION GAUCHE) (x1).
 ARTICLE 4 = M10x1.25x130mm BOULON (x1).
 ARTICLE 5 = M10 RONDELLES (16mm de diamètre) (BLOCKS DE FIXATION) (x4).
 ARTICLE 6 = ENTRETOISE (S0872-58mm de long) (AVANT GAUCHE) (x1).
 ARTICLE 7 = BLOC DE FIXATION GAUCHE (M0437) (x1).
 ARTICLE 8 = ENTRETOISE (S0753) (34mm de long) (x1).
 ARTICLE 9 = M10x1.25x80mm BOULON (ARRIERE GAUCHE) (x1).
 ARTICLE 10 = RONDELLES DE BLOCAGE (LW0001) (x2).
 ARTICLE 11 = ENTRETOISE INTERNE DE LA PROTECTION CRASH (S0727) (5mm de large) (x2).
 ARTICLE 12 = M10x1.25x110mm BOULON (PROTECTION GAUCHE) (x1).
 ARTICLE 13 = M10 RONDELLES (19mm) (PROTECTIONS) (x2).
 ARTICLE 14 = M10x1.25x90mm BOULON (x1).
 ARTICLE 15 = M10x1.25x65mm BOULON (ARRIERE DROIT) (x1).
 ARTICLE 16 = ENTRETOISE (S0778-12mm de long) (PROTECTION DROITE) (x1).
 ARTICLE 17 = ENTRETOISE (S0755-22.5mm de long) (ARRIERE DROITE) (x1).
 ARTICLE 18 = BLOC DE FIXATION ARRIERE DROIT (M0388) (x1).



- ARTICLE 19 = BLOC DE FIXATION AVANT DROIT (M0387) (x1).
 ARTICLE 20 = M10x1.25x80mm BOULON (AVANT DROIT) (x1).
 ARTICLE 21 = M10 CAPUCHON DE BOULON EN PLASTIC (x4) (NON INDIQUE).

Notez que si les kits sont emballés avec des rondelles en caoutchouc servant à tenir les composants, *ces rondelles doivent être jetées.*

OUTILS REQUIS :

- Jeu de clés incluant des clés de 5 & 8mm.
- Jeu de clés incluant des clés de 14 & 17mm.
 - Extensions.
 - Clé Torx T50.
 - Pinces 8 & 14mm.
- Clé dynamométrique (à 40Nm).

ARRIERE MOTO



AVANT MOTO

PHOTO C



PHOTO 1



PHOTO 2



R&G Raci
 worldham,
 01 [www](http://www.r&g.com)

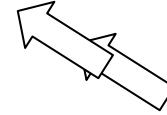

PHOTO 3



PHOTO 5



PHOTO 7

PHOTO 4

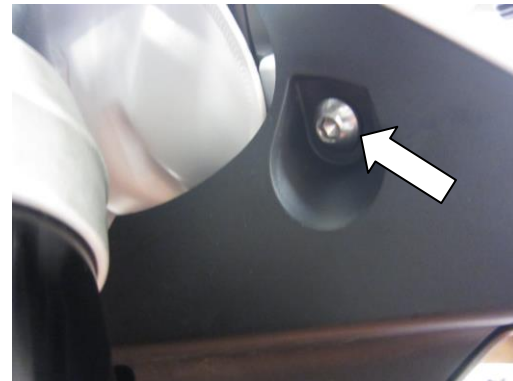

PHOTO 6



PHOTO 8



Photo 9



Photo 10



Photo 11



Photo 12

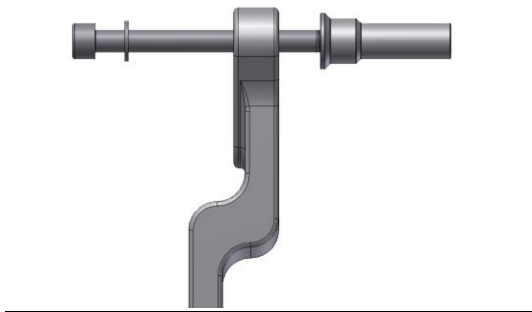

Photo 13

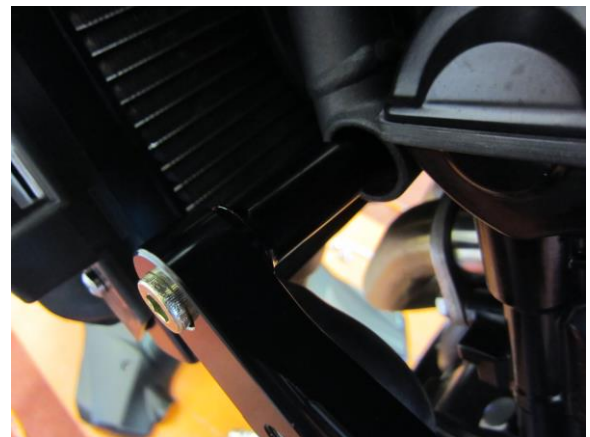

Photo 14



Photo 15



Photo 16

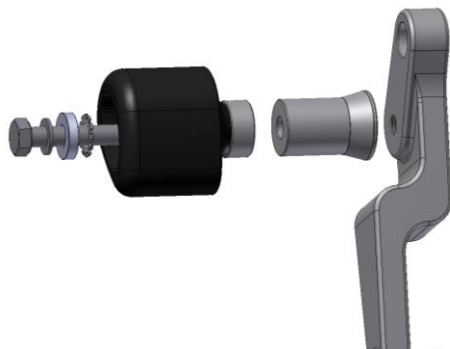

Photo 17



Photo 18



Photo 19



Photo 20



Photo 21



Photo 22



Photo 23



Photo 24

INSTRUCTIONS DE MONTAGE :

Coté gauche (assis sur la moto)

- Enlever les carénages de radiateur des deux cotés de la moto. Pour cela, enlever les boulons et rivets plastic, voir photos 1 à 8 et déconnecter les prises de fils de clignotants.
- Enlever le boulon qui fixe la bas du radiateur en place, voir photo 9.
- Enlever le boulon qui fixe le haut du radiateur en place, voir photo 10.
- Cela devrait permettre au radiateur se s'incliner vers l'avant, donnant plus d'accessibilité, voir photo 11.
- Enlever le boulon moteur/cadre du coté gauche de la moto, voir photo 12. *Il y a un écrou à l'arrière du boulon qui peut être accessible grâce à une pince 14mm par le dessous ou une clé 14mm avec une extension de l'autre coté de la moto. Il y aura*

R&G Racing

Unit 1, Shelley's Lane, East Worldham, Alton, Hampshire, GU34 3AQ

Tel: +44 (0)1420 89007 Fax: +44 (0)1420 87301 www.rg-racing.com Email: info@rg-racing.com



également une entretoise qui risque de tomber. Elle devra être réinsérée lors de l'installation du kit de protection et se place entre le cadre et le moteur.

- Insérer une des rondelles M10 (article 5) sur le boulon M10 x 1.25 x 130mm (article 4) et positionnez la dans le trou de fixation avant du coté gauche du bloc de métal (article 7 – M0437). Placer la longue entretoise (article 6 – S0872 – 58mm de long) sur l'extrémité fileté avec le diamètre le plus large contre le bloc de métal, voir photo 13.
- Monter l'ensemble sur la moto, en veillant à ce que la partie dépassante du boulon se place dans le patron avant du moteur/cadre, en prenant soin de remettre l'entretoise d'origine pendant l'installation. Une fois place, remettre l'écrou d'origine sur l'extrémité du boulon puis serrer légèrement, voir photo 14.
- Enlever le boulon moteur/cadre arrière du coté gauche de la moto, voir photo 15. Il y a une autre *entretoise qui tombera et devra être réutilisée*.
- Placer l'entretoise (article 8 – S0753 – 34mm de long) dans le patron de cadre et bouger le bloc de fixation en place sur le haut, en veillant à ce que les trous s'alignent.
- Insérer une rondelle M10 (article 5) sur le boulon M10 x 1.25 x 80mm (article 9) et positionnez la dans le trou de fixation arrière du coté gauche du bloc de métal, puis dans l'entretoise du support cadre/moteur, en vous assurant que l'entretoise d'origine est correctement replacée entre le cadre et le moteur, avant de serrer légèrement, voir photo 14.
- Ces deux boulons moteur/cadre peuvent à présent être serrés aux couples de serrage recommandés et montés avec les capuchons plastic (article 21).
- La protection crash peut à présent être montée. Glisser une des rondelles M10 (article 13) sur le boulon M10 x 1.25 x 110mm (article 12) de façon à ce que la rondelle se place contre la tête du boulon.
- Glisser une des petites entretoises (article 11-5mm de large) sur le boulon de façon à ce qu'elle se place contre la rondelle tout juste insérée.
- Glisser une rondelle de blocage crantée (article 10) sur le boulon de façon à ce qu'elle se place contre l'entretoise tout juste insérée
- Glisser ensuite le boulon avec rondelles dans la protection crash (article 2) de façon à ce que la tête du boulon et les rondelles aillent dans le contre alésage de la protection crash, puis dans la longue entretoise chanfrein (article 3 – S0873 – 45mm de long) avec le plus petit diamètre contre la protection crash, voir photo 17.
- Monter la protection crash sur le bloc de fixation puis serrer le boulon, voir photos 17 & 18.
- Serrer le boulon de la protection jusqu'à ce que vous sentiez une compression de l'intérieur de la protection avec une clé de 17mm. **LA PROTECTION DOIT ETRE POSITIONNEE COMME EN "C" AVEC LE COTE ARRONDI LE PLUS GROS EN DIRECTION DE L'AVANT DE LA MOTO.** Tourner un peu plus afin d'accroître légèrement la compression. Faire un quart de tour. Pas plus de 40 Nm de couple - Ne pas trop serrer, au risque d'abîmer les composants.



Coté droit (assis sur la moto)

- Enlever le boulon moteur/cadre avant du coté droit de la moto, voir photo 19. *Il y a un écrou à l'arrière du boulon qui peut être accessible grâce à une pince 14mm par le dessous ou une clé 14mm avec une extension de l'autre coté de la moto*
- Insérer une des plus petites rondelles M10 (article 5) sur le boulon M10 x 1.25 x 80mm (article 20) et positionner la dans le creux de trou de fixation du bloc de métal avant droit (article 19 – M0438).
- Monter cet ensemble sur la moto, en veillant à ce que le filetage qui dépasse se place dans le patron de moteur/cadre. Une fois en place, remettre l'écrou d'origine sur l'extrémité du boulon, puis serrer légèrement, voir photo 19.
- Enlever le boulon moteur/cadre arrière du coté droit de la moto, voir photo 20.
- Insérer une des petites rondelles M10 (article 5) sur le boulon M10 x 1.25 x 65mm (article 15) et positionnez la dans le trou de fixation du bloc de métal coté droit (article 18 – M0388), puis dans l'entretoise restante (article 17 – S0755 – 22.5mm de long) et dans le support moteur/cadre, avant de serrer légèrement, voir photo 21.
- Les deux blocs peuvent à présent être alignés sur la moto, de façon à ce que le trou du bloc supérieur s'aligne avec le trou fileté sur le bloc derrière. Il y a également un creux usiné à l'arrière du bloc supérieur qui se positionnera autour du bloc arrière, voir photo 22.
- La protection crash peut à présent être montée. Glisser une des entretoises 10mm (article 13) sur le boulon M10 x 1.25 x 90mm (article 14) de façon à ce que la rondelle se place contre la tête du boulon.
- Glisser une des petites entretoises (article 11-5mm de large) sur le boulon de façon à ce qu'elle se place contre la rondelle tout juste insérée.
- Glisser une des rondelles de blocage (article 10) sur le boulon de façon à ce qu'elle se place contre l'entretoise tout juste insérée.
- Glisser ensuite le boulon avec ses rondelles dans la protection crash (article 2) de façon à ce que la tête du boulon et les rondelles se positionnent dans le contre alésage de la bobine, et autour de la petite entretoise chanfrein (article 16 – S0778 – 12mm long). Positionner la protection crashes sur le bloc de fixation puis serrer le boulon, voir photos 23 & 24.
- Serrer le boulon de la protection jusqu'à ce que vous sentiez une compression de l'intérieur de la protection avec une clé de 17mm. **LA PROTECTION DOIT ETRE POSITIONNEE COMME EN "C" AVEC LE COTE ARRONDI LE PLUS GROS EN DIRECTION DE L'AVANT DE LA MOTO.** Tourner un peu plus afin d'accentuer légèrement la compression. Faire un quart de tour. Pas plus de 40 Nm de couple - Ne pas trop serrer, au risque d'abîmer les composants.
- Les deux boulons moteur/cadre peuvent à présent être serrés aux couples de serrage recommandés et les capuchons insérés (article 21).
- Remettre les 2 boulons qui fixent le radiateur en place comme à l'origine.
- Remettre les 2 capots de radiateur en place et reconnecter les clignotants comme à l'origine.



- Veiller à ce que les carénages soient correctement montés avec tous les boulons complètement serrés.
- Si cela n'est pas déjà fait, coller les stickers dans le creux des 2 capuchons de la protection.
- Monter les capuchons de protection dans les 2 protections crash.

Ces instructions de montage sont disponibles sur www.rg-racing.com

COUPLES DE SERRAGE

- M4 BOLT = 8Nm
- M5 BOLT = 12Nm
- M6 BOLT = 15Nm
- M8 BOLT = 20Nm
- M10 BOLT = 40Nm
- M10 NYLOC NUT = 40Nm

ISSUE 1 12/05/2015 (NSY)

CONSUMER NOTICE

The catalogue description and any exhibition of samples are only broad indications of the Products and R&G may make design changes which do not diminish their performance or visual appeal and supplying them in such state shall conform to the order. The Buyer acknowledges no representation or warranty (other than as to title) has been given or will apply to the Products other than those in R&G's order or confirmation and the Buyer confirms it has chosen the Products as being of merchantable quality and suitable for its particular purposes. Where R&G fits the Products or undertakes other services it shall exercise reasonable skill and care and rectify any fault free of charge unless the workmanship has been disturbed. The Buyer is responsible for ensuring that the warranty on the motorcycle is not affected by the fitting of the Products. On return of any defective Products R&G shall at its option either supply a replacement or refund the purchase money but shall not be liable if the Products have been modified or used or maintained otherwise than in accordance with R&G's or manufacturer's instructions and good engineering practice or if the defect arises from accident or neglect. Other than identified above and subject to R&G not limiting its liability for causing death and personal injury, it shall not be liable for indirect or consequential loss and otherwise its liability shall be limited to the amounts paid by the Buyer for the Products or the fitting or service concerned. These terms do not affect the Buyer's statutory rights.

R&G RACING RETURNS POLICY (NON-FAULTY GOODS)

Returns must be pre-authorized (if not pre-authorized the return will be rejected). Goods may only be returned direct to us if they were purchased direct from us (customer must prove if necessary). Otherwise to be returned to original vendor. Goods must be in re-sellable condition, in the opinion of R&G Racing. All returns are subject to a 25% restocking and handling fee (25% of the gross value exc. P&P – at the prevailing price at time of purchase). The customer must pay any and all carriage charges. No returns of discontinued products, unless within 14 days of purchase. This policy does not affect your statutory rights and does not refer to faulty goods.

CONSUMER NOTICE

The catalogue description and any exhibition of samples are only broad indications of the Products and R&G may make design changes which do not diminish their performance or visual appeal and supplying them in such state shall conform to the order. The Buyer acknowledges no representation or warranty (other than as to title) has been given or will apply to the Products other than those in R&G's order or confirmation and the Buyer confirms it has chosen the Products as being of merchantable quality and suitable for its particular purposes. Where R&G fits the Products or undertakes other services it shall exercise reasonable skill and care and rectify any fault free of charge unless the workmanship has been disturbed. The Buyer is responsible for ensuring that the warranty on the motorcycle is not affected by the fitting of the Products. On return of any defective Products

R&G Racing

Unit 1, Shelley's Lane, East Worldham, Alton, Hampshire, GU34 3AQ

Tel: +44 (0)1420 89007 Fax: +44 (0)1420 87301 www.rg-racing.com Email: info@rg-racing.com



R&G shall at its option either supply a replacement or refund the purchase money but shall not be liable if the Products have been modified or used or maintained otherwise than in accordance with R&G's or manufacturer's instructions and good engineering practice or if the defect arises from accident or neglect. Other than identified above and subject to R&G not limiting its liability for causing death and personal injury, it shall not be liable for indirect or consequential loss and otherwise its liability shall be limited to the amounts paid by the Buyer for the Products or the fitting or service concerned. These terms do not affect the Buyer's statutory rights.

R&G RACING RETURNS POLICY (NON-FAULTY GOODS)

Returns must be pre-authorized (if not pre-authorized the return will be rejected). Goods may only be returned direct to us if they were purchased direct from us (customer must prove if necessary). Otherwise to be returned to original vendor. Goods must be in re-sellable condition, in the opinion of R&G Racing. All returns are subject to a 25% restocking and handling fee (25% of the gross value exc. P&P – at the prevailing price at time of purchase). The customer must pay any and all carriage charges. No returns of discontinued products, unless within 14 days of purchase. This policy does not affect your statutory rights and does not refer to faulty goods.